



September 21, 2020

The wastewater treatment design calculations for the Saddle Ranch Subdivision were prepared by Tipton Environmental International, Inc., 4446 State Route 132, Batavia, Ohio, 45103. The wastewater treatment specifications and drawings were also prepared by Tipton Environmental International, Inc. I have reviewed the design calculations, specifications and design drawings. I agree they are prepared in accordance with good engineering practices.

Sincerely,

A handwritten signature in blue ink, appearing to read "W.D. Ford".

**PMI**



William D. (Doug) Ford, P.E.



September 21, 2020

Ms. Lorretta Carstens, P.E.  
NPDES Permits, Office of Water Quality  
ARKANSAS ENERGY AND ENVIRONMENT  
DIVISION OF ENVIRONMENTAL QUALITY  
5301 Northshore Drive  
North Little Rock, AR 72118-5328

RE: Saddle Ranch Subdivision  
NPDES Permit Number AR0053210  
Construction Permit No. AR0053210C  
AFIN: 60-05010

Dear Ms. Carstens:

In response to your letter dated September 10, 2020, below is the additional information or corrected pages of the application that you requested.

1. ADEQ Form 1
  - Section A.14, page 4, indicating the design flow to be 0.432 mgd;
  - Section B.5, page 7, indicating that grab samples will be collected;
  - Section B.7, page 7, indicates a population of 600;
  - Section H, attached is an engineer's certification for the design calculation, specifications and drawings.
2. EPA Form 2E
  - Attached is EPA Form 2E.
3. Attached is a map indicating the location of Saddle Ranch Subdivision in relation to the City of Little Rock's city limits and planning/zoning boundary. The map indicates the property is outside the City's boundary. The map source is the City of Little Rock, Planning and Development, Interactive Maps, Planning District map found at [maps.littlerock.gov](http://maps.littlerock.gov).

Please let me know if you need additional information or have any questions.

Respectfully,

A handwritten signature in blue ink, appearing to read 'W. Doug Ford', written in a cursive style.

Wm. Doug Ford, P.E.  
Project Manager

WDF:tlr

Enclosures

cc: Rick Ferguson, Southwest Equity Investments, w/encls.

FERG-11791



September 2, 2020

Mr. Bryan Leamons, P.E.  
Senior Operations Manager  
Office of Water Quality  
ARKANSAS ENERGY AND ENVIRONMENT  
DIVISION OF ENVIRONMENTAL QUALITY  
5301 Northshore Drive  
North Little Rock, AR 72118-5328

RE: Southwest Equity Investments, LLC  
Saddle Ranch Subdivision NPDES Permit Application  
Roland, Arkansas

Dear Mr. Leamons:

On behalf of Saddle Ranch Subdivision, transmitted with this letter is an NPDES Permit Application package. The package include the following documents:

- NPDES Permit Application Form 1
- Non-municipal Domestic Sewage Treatment Works Trust Fund
- Attachments 1 – 12 for Construction Permit Application
- Design Calculations
- Equipment Specifications
- Treatment Plant Drawings
- Arkansas Secretary of State Documents
- Disclosure Statement

Southwest Equity Investments, LLC owns a Tipton Environmental domestic wastewater treatment plant that was designed for Reunion Subdivision in Benton, Arkansas. Southwest Equity Investments, LLC intends on using the domestic wastewater treatment plant for the Saddle Ranch subdivision in Roland, Arkansas. The planned initial phases of the subdivision will not exceed the treatment plant design specifications.



If you have any questions or need additional information, please let me know.

Respectfully,

A handwritten signature in blue ink, appearing to read 'W. Ford', with a stylized flourish at the end.

Wm. Doug Ford, P.E.  
Project Manager

WDF:tlr

Enclosures

cc: Southwest Equity Investments, LLC., w/encls.

FERG-11791

**Arkansas Department of Environmental Quality  
NPDES PERMIT APPLICATION  
FORM 1**

**INSTRUCTIONS:**

1. This form should be **typed or printed in ink**. If insufficient space is available to address any item, please continue on an attached sheet of paper.
2. Please complete the following section(s). If a section is not required, please check the Not Applicable (N/A) box at the top of the section.

Sections	A	B	C	D	E	F	G	H	I
POTW	X	X	X	X					X
Industrial User	X	X	X	X	X	X	X		X
Construction Permit Only	X	X	*	X	X			X	X
Modification	X	X	X	X		*	*	X	X
All Other Applicants	X	X	X	X	X				X

\* As necessary

3. If you need help on SIC or NAICS go to <https://www.naics.com/search/>.

Common SIC and NAICS

Facility Type	SIC Code	NAICS
Publicly Owned Treatment Works (POTW)	4952	221320
Subdivision, Apartment Complex	6552	237210
Mobile Home Park	6515	533190

4. If you have any questions about this form you may call NPDES Section at 501-682-0623 or go to [www.adeq.state.ar.us/water](http://www.adeq.state.ar.us/water). You may also contact :

Department	Information in Regard to	Telephone #
Arkansas Department of Health	Water Supply	501-661-2623

5. The following EPA Forms in addition to Form 1 is required for processing your application:

- Form 2A** - Municipal Dischargers
- Form 2B** - Concentrated Animal Feeding Operations
- Form 2C** - Existing Manufacturing, Commercial, Mining, and Silvicultural Operations
- Form 2D** - New Sources and New Dischargers Application for Permit to Discharge Process Wastewater
- Form 2E** - Facilities Which Do Not Discharge Process Wastewater (i.e. Domestic, Non contact cooling water)
- Form 2F** - Application for Permit to Discharge Storm Water Discharges Associated With Industrial Activity

6. Where to Submit

Return the completed form by mail to:

Arkansas Department of Environmental Quality  
Permits Branch, Office of Water Quality

5301 Northshore Drive  
North Little Rock, AR 72118

Or by email to:

[Water.Permit.Application@adeq.state.ar.us](mailto:Water.Permit.Application@adeq.state.ar.us)

NPDES PERMIT APPLICATION  
**FORM 1**

ARKANSAS DEPARTMENT OF ENVIRONMENTAL QUALITY  
OFFICE OF WATER QUALITY  
5301 Northshore Drive  
North Little Rock, AR 72118-5317  
[www.adeg.state.ar.us/water](http://www.adeg.state.ar.us/water)

**PURPOSE OF THIS APPLICATION**

- INITIAL PERMIT APPLICATION FOR NEW FACILITY
- INITIAL PERMIT APPLICATION FOR EXISTING FACILITY
- MODIFICATION OF EXISTING PERMIT
- REISSUANCE (RENEWAL) OF EXISTING PERMIT
- MODIFICATION AND CONSTRUCTION OF EXISTING PERMIT
- CONSTRUCTION PERMIT

**SECTION A- GENERAL INFORMATION**

1. Legal Applicant Name (The permit will be issued under this name. This is the entity that controls and is responsible for operations and compliance.):

Southwest Equity Investments, LLC

Note: The legal name of the applicant must be identical to the name listed with the Arkansas Secretary of State.

2. Operator Type: Private  State  Federal  Partnership  Corporation  Other

State of Incorporation: Arkansas

3. Facility Name: Saddle Ranch Subdivision WWTP

4. Is the legal applicant identified in number 1 above, the owner of the facility?  Yes  No

5. NPDES Permit Number (If Applicable): AR00

6. NPDES General Permit Number (If Applicable): ARG

7. NPDES General Storm Water Permit Number (If Applicable): \_\_\_\_\_

8. Permit Numbers and/or names of any permits issued by ADEQ or EPA for an activity located in Arkansas that is presently held by the applicant or its parent or subsidiary corporation which are not listed above:

<u>Permit Name</u>	<u>Permit Number</u>	<u>Held by</u>
Waterview Estates/PH II	AR0050393	Waterview Estates POA
Waterview Estates/PH II	ARR150142	Waterview Estates, LLC

9. Give driving directions to the wastewater treatment plant with respect to known landmarks:

From HWY 300 in Roland, AR take Roland Cutoff Rod. East approximately 1.62 miles. The facility will be located on the north side of the road.

10. Facility Physical Location: (Attach a map with location marked; street, route no. or other specific identifier)

Street: Roland Cutoff  
City: Roland County: Pulaski State: AR Zip: 72135

11. Facility Mailing Address for permit, DMR, and invoice (Street or Post Office Box):

Name: Saddle Ranch Subdivision WWTP Title: \_\_\_\_\_  
Street: \_\_\_\_\_ P.O. Box 23070  
City: Little Rock State: AR Zip: 72221  
E-mail address\*: rickferguson777@gmail.com Fax: \_\_\_\_\_

\* Is emailing all documents (permit, letters, DMRs, invoices, etc.) acceptable to the applicant?  Yes  No

12. Neighboring States Within 20 Miles of the permitted facility (Check all that apply):

Oklahoma  Missouri  Tennessee  Louisiana  Texas  Mississippi

13. Indicate applicable Standard Industrial Classification (SIC) Codes and NAICS codes for primary processes (See Item #3 of the instructions for assistance in determining the correct SIC and NAICS Codes):

4952 SIC Facility Activity under this SIC or NAICS:  
221320 NAICS Sewage Treatment Facilities

14. Design Flow: 0.432 MGD Highest Monthly Average of the last two years Flow: N/A MGD

15. Is the outfall equipped with a diffuser?  Yes  No

16. Responsible Official (as described on the last page of this application):

Name: Rick Ferguson Title: President  
Address: P.O. Box 23070 Phone Number: 501-868-8855  
E-mail Address: rickferguson777@gmail.com  
City: Little Rock State: AR Zip: 72221

17. Cognizant Official (Duly Authorized Representative of responsible official as described on the last page of this application):

Name: Brock Ferguson Title: General Manager  
Address: P.O. Box 23070 Phone Number: 501-868-8855  
E-mail Address: brockferg31@gmail.com  
City: Little Rock State: AR Zip: 72221

18. Name, address and telephone number of active consulting engineer firm (If none, so state):

Contact Name: Brad Wingfield, P.E.  
Company Name: PMI  
Address: 3512 S. Shackelford Road Phone Number: 501-221-7122  
E-mail Address: bwingfiled@pmico.com  
City: Little Rock State: AR Zip: 72205

19. Wastewater Operator Information

Wastewater Operator Name: Arlo Jason Cyz License number: 007231

Class of municipal wastewater operator: I  II  III  IV

Class of industrial wastewater operator: Basic  Advanced

**SECTION B: FACILITY AND OUTFALL INFORMATION**

1. Facility Location (All information must be based on the **front door (gate)** location of the facility):

Lat: N 34 ° 53 ' 58.39 " Long: W 92 ° 31 ' 28.06 " County: Pulaski Nearest Town: Roland

2. **Outfall** Location (The location of the end of the pipe discharge point.):

**Outfall No. 001:**

Latitude: N 34 ° 54 ' 7.50 " Longitude: W 92 ° 31 ' 24.80 "

Description of outfall location: End of pipe

Name of Receiving Stream (i.e. an unnamed tributary of Mill Creek, thence into Mill Creek; thence into Arkansas River):

An unnamed tributary of Mill Bayou, thence into Mill Bayou, thence into Murray Lake, thence into Arkansas River.

**Outfall No. \_\_\_\_\_:**

Latitude: \_\_\_\_\_ ° \_\_\_\_\_ ' \_\_\_\_\_ " Longitude: \_\_\_\_\_ ° \_\_\_\_\_ ' \_\_\_\_\_ "

Description of outfall location: \_\_\_\_\_

Name of Receiving Stream (i.e. an unnamed tributary of Mill Creek, thence into Mill Creek; thence into Arkansas River):

3. **Monitoring** Location (If the monitoring is conducted at a location different than the above **Outfall** location):

**Outfall No. \_\_\_\_\_:**

Lat: \_\_\_\_\_ ° \_\_\_\_\_ ' \_\_\_\_\_ " Long: \_\_\_\_\_ ° \_\_\_\_\_ ' \_\_\_\_\_ "

**Outfall No. \_\_\_\_\_:**

Lat: \_\_\_\_\_ ° \_\_\_\_\_ ' \_\_\_\_\_ " Long: \_\_\_\_\_ ° \_\_\_\_\_ ' \_\_\_\_\_ "

**Outfall No. \_\_\_\_\_:**

Lat: \_\_\_\_\_ ° \_\_\_\_\_ ' \_\_\_\_\_ " Long: \_\_\_\_\_ ° \_\_\_\_\_ ' \_\_\_\_\_ "

4. Type of Treatment system (Include all components of the treatment system and attach the process flow diagram):

Individual septic tanks at homes, EQ chamber, sludge holding chamber, aeration chamber, clarifiers, filtration, chlorine disinfection, dechlorination, flow monitoring.

5. FLOW AND SAMPLE MEASUREMENT

How are effluent samples collected?

Samples will be collected at the end of the pipe via grab sampling.

How is flow measured, i.e., v-notch weir, totalizing meter, Parshall flume, etc.?

Totalizing meter

6. Is the proposed or existing facility located above the 100-year flood level?  Yes  No

NOTE: FEMA Map must be included with this application. Maps can be ordered at <https://msc.fema.gov>.

If "No", what measures are (or will be) used to protect the facility? \_\_\_\_\_

7. Population for Municipal and Domestic Sewer Systems: 600

8. Backup Power Generation for Treatment Plants

Are there any permanent backup generators? Yes  No

If Yes, how many? 1 Total Horsepower (hp)? 40

If no, please explain. Include a description of how the WWTP will be restarted and actions taken to ensure compliance with permit limits once power is restored.



**SECTION C – WASTE STORAGE AND DISPOSAL INFORMATION**

1. Sludge Disposal Method (Check as many as are applicable):

**Landfill**

Landfill Site Name Republic Services Saline County Landfill ADEQ Solid Waste Permit No. \_\_\_\_\_

**Land Application:** ADEQ State Permit No. \_\_\_\_\_

**Septic tank** Arkansas Department of Health Permit No.: \_\_\_\_\_

**Distribution and Marketing:** Facility receiving sludge:

Name: \_\_\_\_\_ Address: \_\_\_\_\_

City: \_\_\_\_\_ State: \_\_\_\_\_ Zip: \_\_\_\_\_ Phone: \_\_\_\_\_

Rail:  \_\_\_\_\_ Pipe:  \_\_\_\_\_ Other: \_\_\_\_\_

**Subsurface Disposal** (Lagoon for which the sole purpose is storing sludge):

Location of lagoon \_\_\_\_\_ How old is the lagoon? \_\_\_\_\_

Surface area of lagoon: \_\_\_\_\_ Acre Depth: \_\_\_\_\_ ft Does lagoon have a liner?  Yes  No

**Incineration:** Location of incinerator \_\_\_\_\_

**Remains in Treatment Lagoon(s):**

How old is the lagoon(s)? \_\_\_\_\_ Has sludge depth been measured?  Yes  No

If Yes, Date measured? \_\_\_\_\_ Sludge Depth? \_\_\_\_\_ ft If No, When will it be measured? \_\_\_\_\_

Has sludge ever been removed? Yes  No  If Yes, When was it removed? \_\_\_\_\_

**Other** (Provide complete description): \_\_\_\_\_

**SECTION D - WATER SUPPLY**

Water Sources which are downstream of the outfall location, i.e., those which could be affected by the discharge from this facility (check as many as are applicable):

**Private Well** - Distance from Discharge point:  Within 5 miles  Within 50 miles

**Municipal Water Utility** (Specify City): Maumelle

Distance from Discharge point:  Within 5 miles  Within 50 miles

**Surface Water**- Name of Surface Water Source: Murray Lake

Distance from Discharge point:  Within 5 miles  Within 50 miles

Lat: 34 ° 52 ' 21.38 " Long: 92 ° 28 ' 13.35 "

**Other** (Specify): \_\_\_\_\_

Distance from Discharge point:  Within 5 miles  Within 50 miles

## SECTION E: TRUST FUND REQUIREMENTS AND DISCLOSURE STATEMENT

1. Ark. Code Ann. § 8-4-203(b)(1)(A) forbids the Arkansas Department of Environmental Quality from issuing, modifying, renewing, or transferring a permit for a nonmunicipal domestic sewage treatment works without the applicant first fulfilling the trust fund requirements set forth in that section. Ark. Code Ann. § 8-4-203(b)(1)(B) defines “nonmunicipal domestic sewage treatment works” as a device or system operated by an entity other than a city, town, or county that treats, in whole or in part, waste or wastewater from humans or household operations and must continually operate to protect human health and the environment despite a permittee’s failure to maintain or operate the device or system. NDSTW’s can include, but are not limited to:

- Sewer Improvement Districts;
- Subdivisions,
- Mobile Home Parks,
- Property Owner’ Associates,
- RV parks, and
- Apartments

**Exclusions** Excluded from this application’s Section E.1. requirements for trust fund contribution fees are:

- State or federal facilities,
- Schools,
- Universities and colleges,
- Entities that continuously operate due to a connection with a city, town, or county, and
- Commercial or industrial entity that treats domestic sewage from its operations and does not accept domestic sewage from other entities or residences.

The trust fund form may be obtained from the ADEQ web site at:

<https://www.adeg.state.ar.us/water/permits/npdes/individual/pdfs/ndstw-trust-fund-certification-form.pdf>

2. Disclosure Statement:

Ark. Code Ann. 8-1-106 requires that applicants for any type of permit or transfer of any permit, license, certification or operational authority issued by the Arkansas Department of Environmental Quality (ADEQ) file a Disclosure Statement with their application unless exempt for doing so under Ark. Code Ann. §8-1-106(b)(2). The filing of a Disclosure Statement is mandatory. No application can be considered administratively complete without a completed Disclosure Statement unless that facility is exempt. Publicly traded companies may submit the most recent 10k and 10Q filings to the Securities and Exchange Commission in lieu of the Disclosure Statement. The form may be obtained from the ADEQ web site at:

[https://www.adeg.state.ar.us/ADEQ\\_Disclosure\\_Statement.pdf](https://www.adeg.state.ar.us/ADEQ_Disclosure_Statement.pdf)

**Nonmunicipal Domestic Sewage Treatment Works Trust Fund Certification Form**

Permittee (Legal) Name: Southwest Equity Investments, LLC  
 Facility Name: Saddle Ranch Subdivision  
 Permit No. \_\_\_\_\_

**Section A – Information Requiring Engineering Certification**

**Part I – Operating and Maintenance Expenses**

	Units/Year	Unit Cost	Annual Cost	5-Year Cost <sup>1</sup>
<b>Operating Expenses</b>				
Operating Labor <sup>2</sup>	12	1400	16,800	89,040
Electricity <sup>3</sup>	12	400	4,800	25,440
Supplies & Chemicals	12	1400	16,800	89,040
Analytical Testing	12	250	3,000	15,900
Generator Fuel	12	20	240	1,272
Other	12	50	600	3,180
<b>Maintenance Expenses</b>				
Maintenance Labor <sup>2</sup>	12	500	6,000	31,800
Parts & Supplies	12	200	2,400	12,720
Other	12	50	600	3,180
<b>Administrative Expenses</b>				
Administrative Labor <sup>2</sup>	12	200	2,400	12,720
Customer Fee Collection	12	750	9,000	47,700
Insurance & Bonding	12	300	3,600	19,080
Consulting and Legal Fees	2	100	200	1,060
Interest Expenses	—	NA	N/A	N/A
Property Taxes	1	400	400	2,120
Permit Fees	1	200	200	1,060
<b>Other Miscellaneous Expenses</b>	12	50	600	3,180
<b>TOTAL</b>		6,270	75,240	358,492

<sup>1</sup> Assuming no inflation data are available, assume an inflation rate of 3% in years two through five and multiply the annual cost by 5.3 to estimate the five-year cost.

<sup>2</sup> Labor costs must include fringe benefits and payroll taxes.

<sup>3</sup> For existing facilities, include historical data if they are representative of future operations. For new facilities, show the electricity consumption calculations in kilowatt hours (kWh).

**Part II – Capital Expenditures**

- The wastewater treatment plant (WWTP) must be examined by a Professional Engineer registered in the State of Arkansas to determine all necessary capital expenditures, system upgrades, or significant repairs which may be needed within the following five (5) years. **A list of all of these items must be attached to this document.**
- A milestone schedule for completion of the capital expenditures, system upgrades, or significant repairs **must be attached to this document.**

**Nonmunicipal Domestic Sewage Treatment Works Trust Fund Certification Form**

**Part III – Financial Plan**

A financial plan that demonstrates to the Department's satisfaction the permittee's ability to operate and maintain the WWTP for five (5) years must be prepared. This plan should also include a comprehensive connection summary listing the number of connections and types of connections based on Appendix B of the Arkansas Department of Health Rules and Regulations Pertaining to Onsite Wastewater Systems. The summary should include the number of existing connections and an estimated number of new connections for the next five (5) years. *The financial plan must be attached to this document.*

**Part IV – Certification**

I certify under penalty of law that this document and all attachments were prepared under my direction or supervision in accordance with a system designed to assure that qualified personnel properly gather and evaluate the information submitted. Based on my inquiry of the person or persons who manage the system, or those persons directly responsible for gathering the information, the information submitted is, to the best of my knowledge and belief, true, accurate, and complete. I am aware that there are significant penalties for submitting false information, including the possibility of fine and imprisonment for knowing violations.

Printed Name of AR Professional Engineer: William D. Ford

Registration License Number: 7040

Signature of AR Professional Engineer: W<sup>M</sup> D<sub>2</sub> F

Date: 8-24-20 Telephone Number: 501-221-7122

E-mail: d.ford@pmico.com Fax Number: 501-221-7775

Stamp of AR Professional Engineer

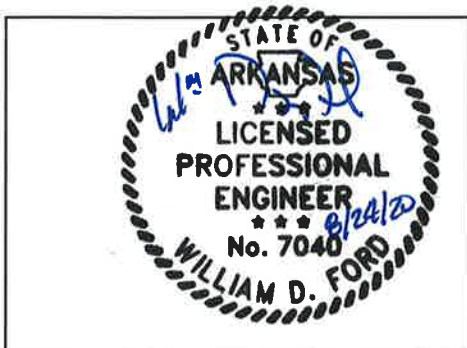

Nonmunicipal Domestic Sewage Treatment Works Trust Fund Certification Form

*Section B – Service Area Information and Certification of Compliance*

**Part I – Legal Description**

A legal description of the service area *must be attached to this document*. This requirement may be satisfied by providing a plat for the area served by the non-municipal domestic sewage treatment works.

**Part II – Potable Water Sources**

A list of the sources of the potable water for the service area *must be attached to this document*.

**Part III – Certification of Compliance**

Has the permit applicant complied with all local zoning ordinances, local planning authority regulations, local permitting requirements, and any other applicable local regulations necessary for the construction and operation of this facility?

Yes ✓ No \_\_\_\_\_

I certify under penalty of law that this document and all attachments were prepared under my direction or supervision in accordance with a system designed to assure that qualified personnel properly gather and evaluate the information submitted. Based on my inquiry of the person or persons who manage the system, or those persons directly responsible for gathering the information, the information submitted is, to the best of my knowledge and belief, true, accurate, and complete. I am aware that there are significant penalties for submitting false information, including the possibility of fine and imprisonment for knowing violations.

Printed Name of Permittee Responsible Official: Rick Ferguson

Signature of Permittee Responsible Official: [Signature]

Date: 9-1-20 Telephone Number: 501-221-1888

E-mail: ferguson.office@gmail.com Fax Number: \_\_\_\_\_

**SECTION F – INDUSTRIAL ACTIVITY**

1. Does an effluent guideline limitation promulgated by EPA ([Link to a Listing of the 40 CFR Effluent Limit Guidelines](#)) under Section 304 of the Clean Water Act (CWA) apply to your facility?

YES  (Answer questions 2 and 3)      NO

2. What Part of 40 CFR? \_\_\_\_\_

3. What Subpart(s)? \_\_\_\_\_

4. Give a brief description of all operations at this facility including primary products or services (attach additional sheets if necessary):

---



---



---

5. Production: (projected for new facilities)

Product(s) Manufactured (Brand name)	Last 12 Months		Highest Production Year of Last 5 Years	
	lbs/day*		lbs/day*	
	Highest Month	Days of Operation	Monthly Average	Days of Operation

\* These units could be off-lbs, lbs quenched, lbs cleaned/etched/rinsed, lbs poured, lbs extruded, etc.







## SECTION H -TECHNICAL INFORMATION

Technical information to support this application shall be furnished in appropriate detail to understand the project. Information in this Part is required for obtaining a **construction permit** or for **modification** of the treatment system.

1. Describe the treatment system. Include the types of control equipment to be installed along with their methods of operation and control efficiency.

The treatment plant is an extended air, activated sludge treatment process, with chlorine disinfection.

---

---

---

2. One set of construction plans and specifications, approved (Signed and stamped) by a **Professional Engineer** (PE) registered in **Arkansas**, must be submitted as follows:
  - a. The plans must show flow rates in addition to pertinent dimensions so that detention times, overflow rates, and loadings per acre, etc. can be calculated.
  - b. Specifications and complete design calculations.
  - c. All treated wastewater discharges should have a flow measuring device such as a weir or Parshall flume installed. Where there is a significant difference between the flow rates of the raw and treated wastewater, a flow measuring device should be provided both before and after treatment.
3. If this application includes a construction permit disturbing five or more acres, a storm water construction permit must be obtained by submitting a notice of intent (NOI) to ADEQ.

**SECTION I: SIGNATORY REQUIREMENTS**

**Cognizant Official (Duly Authorized Representative)**

40 CFR 122.22(b) states that all reports required by the permit, or other information requested by the Director, shall be signed by the applicant (or person authorized by the applicant) or by a duly authorized representative of that person. A person is a duly authorized representative only if:

- (1) the authorization is made in writing by the applicant (or person authorized by the applicant);
- (2) the authorization specifies either an individual or a position having responsibility for the overall operation of the regulated facility or activity responsibility, or an individual or position having overall responsibility for environmental matters for the company.

The applicant hereby designates the following person as a Cognizant Official, or duly authorized representative, for signing reports, etc., including Discharge Monitoring Reports (DMR) required by the permit, and other information requested by the Director:

Signature of Cognizant Official:  Date: 8/24/2018

Printed name of Cognizant Official: Brock Ferguson

Official title of Cognizant Official: General Manager Telephone Number: 501-868-8855

**Responsible Official**

The information contained in this form must be certified by a responsible official as defined in the "signatory requirements for permit applications" (40 CFR 122.22).

Responsible official is defined as follows:

- Corporation**, a principal officer of at least the level of vice president
- Partnership**, a general partner
- Sole proprietorship**: the proprietor
- Municipal, state, federal, or other public facility**: principal executive officer, or ranking elected official.

RF (initial) "I certify that the cognizant official designated above is qualified to act as a duly authorized representative under the provisions of 40 CFR 122.22(b)." NOTE: If no duly authorized representative is designated in this section, the Department considers the applicant to be the responsible official for the facility and only reports, etc., signed by the applicant will be accepted by the Department.

RF (initial) "I certify that, if this facility is a corporation, it is registered with the Secretary of State in Arkansas. Please provide the full name of the corporation if different than that listed in Section A above."

"I certify under penalty of law that this document and all attachments were prepared under my direction or supervision in accordance with a system designed to assure that qualified personnel properly gather and evaluate the information submitted. Based on my inquiry of the person or persons who manage the system, or those persons directly responsible for gathering the information, the information submitted is, to the best of my knowledge and belief, true, accurate, and complete. I am aware that there are significant penalties for submitting false information including the possibility of fine and imprisonment for knowing violations. I further certify under penalty of law that all analyses reported as less than detectable in this application or attachments thereto were performed using the EPA approved test method having the lowest detection limit for the substance tested."

Signature of Responsible Official:  Date: 8-24-20

Printed name of Responsible Official: Rick Ferguson

Official title of Responsible Official: President Telephone Number: 501-868-8855

# ADEQ CONSTRUCTION PERMIT APPLICATION

FORM 2E NPDES		<b>U.S. Environmental Protection Agency</b> <b>Application for NPDES Permit to Discharge Wastewater</b> <b>MANUFACTURING, COMMERCIAL, MINING, AND SILVICULTURAL FACILITIES WHICH DISCHARGE ONLY NONPROCESS WASTEWATER</b>
---------------------	--	---

**SECTION 1. OUTFALL LOCATION (40 CFR 122.21(h)(1))**

Outfall Location	1.1	Provide information on each of the facility's outfalls in the table below.			
		<b>Outfall Number</b>	<b>Receiving Water Name</b>	<b>Latitude</b>	<b>Longitude</b>
		001	Mill Bayou	34° 53' 58.39" N	92° 31' 28.06" W
				° ' "	° ' "

**SECTION 2. DISCHARGE DATE (40 CFR 122.21(h)(2))**

Discharge Date	2.1	Are you a new or existing discharger? (Check only one response.) <input checked="" type="checkbox"/> New discharger <input type="checkbox"/> Existing discharger → SKIP to Section 3.
	2.2	Specify your anticipated discharge date: 03/01/2021

**SECTION 3. WASTE TYPES (40 CFR 122.21(h)(3))**

Waste Types	3.1	What types of wastes are currently being discharged if you are an existing discharger or will be discharged if you are a new discharger? (Check all that apply.) <input checked="" type="checkbox"/> Sanitary wastes <input type="checkbox"/> Other nonprocess wastewater (describe/explain directly below) <input type="checkbox"/> Restaurant or cafeteria waste <input type="checkbox"/> Non-contact cooling water
	3.2	Does the facility use cooling water additives? <input type="checkbox"/> Yes <input checked="" type="checkbox"/> No → SKIP to Section 4.
	3.3	List the cooling water additives used and describe their composition.

Cooling Water Additives (list)	Composition of Additives (if available to you)

**SECTION 4. EFFLUENT CHARACTERISTICS (40 CFR 122.21(h)(4))**

Effluent Characteristics	4.1	Have you completed monitoring for all parameters in the table below at each of your outfalls and attached the results to this application package? <input type="checkbox"/> Yes <input checked="" type="checkbox"/> No; a waiver has been requested from my NPDES permitting authority (attach waiver request and additional information) → SKIP to Section 5.						
	4.2	Provide data as requested in the table below. <sup>1</sup> (See instructions for specifics.)						
		<b>Parameter or Pollutant</b>	<b>Number of Analyses</b> (if actual data reported)	<b>Maximum Daily Discharge</b> (specify units)		<b>Average Daily Discharge</b> (specify units)	<b>Source</b> (use codes per instructions)	
				<b>Mass</b>	<b>Conc.</b>	<b>Mass</b>	<b>Conc.</b>	
		Biochemical oxygen demand (CBOD)			8.4 mg/L		<4 mg/L	3
		Total suspended solids (TSS)			15 mg/L		<6 mg/L	3
		Oil and grease			<5mg/L		<5mg/L	3
		Ammonia (as N)			16mg/L		<4 mg/L	3
		Discharge flow		50,000 gpd				3
		pH (report as range)		(6.4-7.3) s.u.				3
	Temperature (winter)							
	Temperature (summer)							

<sup>1</sup> Sampling shall be conducted according to sufficiently sensitive test procedures (i.e., methods) approved under 40 CFR 136 for the analysis of pollutants or pollutant parameters or required under 40 CFR chapter I, subchapter N or O. See instructions and 40 CFR 122.21(e)(3).

Effluent Characteristics Continued	4.3	Is fecal coliform believed present, or is sanitary waste discharged (or will it be discharged)? <input checked="" type="checkbox"/> Yes <input type="checkbox"/> No → SKIP to Item 4.5.						
	4.4	Provide data as requested in the table below. <sup>1</sup> (See instructions for specifics.)						
		<b>Parameter or Pollutant</b>	<b>Number of Analyses</b> <small>(if actual data reported)</small>	<b>Maximum Daily Discharge</b> <small>(specify units)</small>		<b>Average Daily Discharge</b> <small>(specify units)</small>		<b>Source</b> <small>(Use codes per instructions.)</small>
				<b>Mass</b>	<b>Conc.</b>	<b>Mass</b>	<b>Conc.</b>	
		Fecal coliform						
		<i>E. coli</i>						
		Enterococci						
	4.5	Is chlorine used (or will it be used)? <input checked="" type="checkbox"/> Yes <input type="checkbox"/> No → SKIP to Item 4.7.						
	4.6	Provide data as requested in the table below. <sup>1</sup> (See instructions for specifics.)						
		<b>Parameter or Pollutant</b>	<b>Number of Analyses</b> <small>(if actual data reported)</small>	<b>Maximum Daily Discharge</b> <small>(specify units)</small>		<b>Average Daily Discharge</b> <small>(specify units)</small>		<b>Source</b> <small>(use codes per instructions)</small>
			<b>Mass</b>	<b>Conc.</b>	<b>Mass</b>	<b>Conc.</b>		
	Total Residual Chlorine			0.8 mg/L		0.4 mg/L	3	
4.7	Is non-contact cooling water discharged (or will it be discharged)? <input type="checkbox"/> Yes <input checked="" type="checkbox"/> No → SKIP to Section 5.							
4.8	Provide data as requested in the table below. <sup>1</sup> (See instructions for specifics.)							
	<b>Parameter or Pollutant</b>	<b>Number of Analyses</b> <small>(if actual data reported)</small>	<b>Maximum Daily Discharge</b> <small>(specify units)</small>		<b>Average Daily Discharge</b> <small>(specify units)</small>		<b>Source</b> <small>(use codes per instructions)</small>	
			<b>Mass</b>	<b>Conc.</b>	<b>Mass</b>	<b>Conc.</b>		
	Chemical oxygen demand (COD)							
	Total organic carbon (TOC)							

**SECTION 5. FLOW (40 CFR 122.21(h)(5))**

Flow	5.1	Except for stormwater water runoff, leaks, or spills, are any of the discharges you described in Sections 1 and 3 of this application intermittent or seasonal? <input type="checkbox"/> Yes → Complete this section. <input checked="" type="checkbox"/> No → SKIP to Section 6.				
	5.2	Briefly describe the frequency and duration of flow.				

**SECTION 6. TREATMENT SYSTEM (40 CFR 122.21(h)(6))**

Treatment System	6.1	Briefly describe any treatment system(s) used (or to be used). The treatment plant is an extended air, activated sludge treatment process, with chlorine disinfection				
------------------	-----	--	--	--	--	--

<sup>1</sup> Sampling shall be conducted according to sufficiently sensitive test procedures (i.e., methods) approved under 40 CFR 136 for the analysis of pollutants or pollutant parameters or required under 40 CFR chapter I, subchapter N or O. See instructions and 40 CFR 122.21(e)(3).

EPA Identification Number N/A	NPDES Permit Number New Permit	Facility Name Saddle Ranch Subdivision WWTP
----------------------------------	-----------------------------------	--

Form Approved 03/05/19  
OMB No. 2040-0004

**SECTION 7. OTHER INFORMATION (40 CFR 122.21(h)(7))**

Other Information	7.1	Use the space below to expand upon any of the above items. Use this space to provide any information you believe the reviewer should consider in establishing permit limitations. Attach additional sheets as needed.
-------------------	-----	---

**SECTION 8. CHECKLIST AND CERTIFICATION STATEMENT (40 CFR 122.22(a) and (d))**

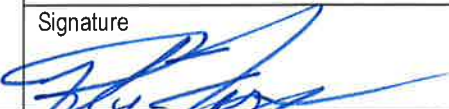
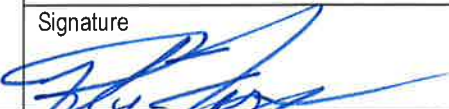
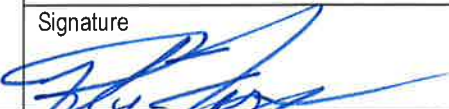
Checklist and Certification Statement	8.1	In Column 1 below, mark the sections of Form 2E that you have completed and are submitting with your application. For each section, specify in Column 2 any attachments that you are enclosing to alert the permitting authority. Note that not all applicants are required to provide attachments.									
		<b>Column 1</b>	<b>Column 2</b>								
		<input checked="" type="checkbox"/> Section 1: Outfall Location	<input type="checkbox"/> w/ attachments (e.g., responses for additional outfalls)								
		<input checked="" type="checkbox"/> Section 2: Discharge Date	<input type="checkbox"/> w/ attachments								
		<input checked="" type="checkbox"/> Section 3: Waste Types	<input type="checkbox"/> w/ attachments								
		<input checked="" type="checkbox"/> Section 4: Effluent Characteristics	<input type="checkbox"/> w/ attachments								
		<input checked="" type="checkbox"/> Section 5: Flow	<input type="checkbox"/> w/ attachments								
		<input checked="" type="checkbox"/> Section 6: Treatment System	<input type="checkbox"/> w/ attachments								
		<input type="checkbox"/> Section 7: Other Information	<input type="checkbox"/> w/ attachments								
		<input checked="" type="checkbox"/> Section 8: Checklist and Certification Statement	<input type="checkbox"/> w/ attachments								
	8.2	<p><b>Certification Statement</b></p> <p><i>I certify under penalty of law that this document and all attachments were prepared under my direction or supervision in accordance with a system designed to assure that qualified personnel properly gather and evaluate the information submitted. Based on my inquiry of the person or persons who manage the system, or those persons directly responsible for gathering the information, the information submitted is, to the best of my knowledge and belief, true, accurate, and complete. I am aware that there are significant penalties for submitting false information, including the possibility of fine and imprisonment for knowing violations.</i></p> <table border="1" style="width: 100%;"> <tr> <td>Name (print or type first and last name)</td> <td>Official title</td> </tr> <tr> <td>Rick Ferguson</td> <td>President</td> </tr> <tr> <td>Signature</td> <td>Date signed</td> </tr> <tr> <td></td> <td>9-21-20</td> </tr> </table>		Name (print or type first and last name)	Official title	Rick Ferguson	President	Signature	Date signed		9-21-20
Name (print or type first and last name)	Official title										
Rick Ferguson	President										
Signature	Date signed										
	9-21-20										



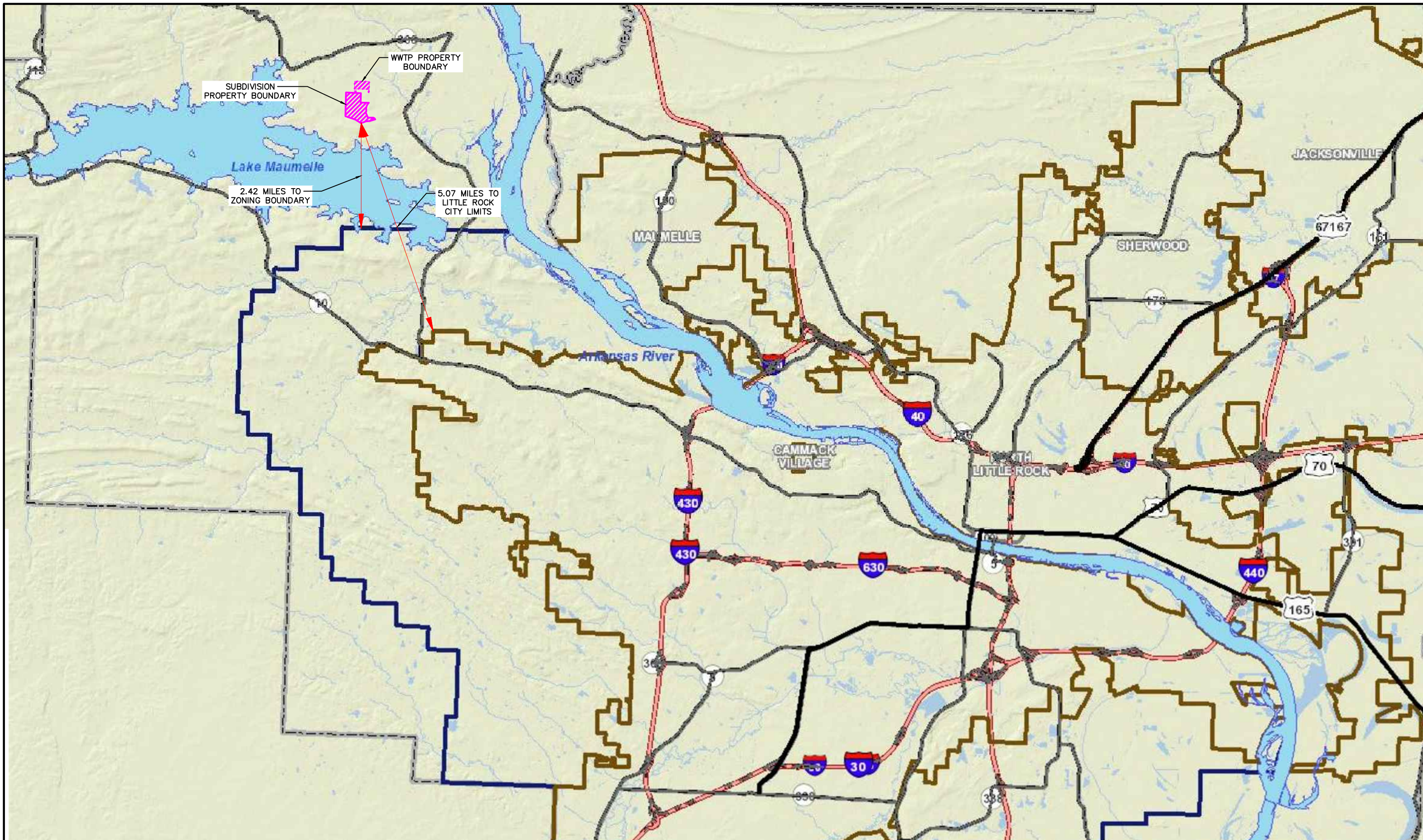

**CIVIL ENGINEERING AND ENVIRONMENTAL SERVICES**  
 3512 South Shackleford Road  
 Little Rock, Arkansas 72205  
 (501) 221-7122 fax (501) 221-7775

SUBMITTED:	D. FORD
DRAWN:	C. GLOVER
CHECKED:	D. FORD
DATE:	SEP. 18, 2020



**SCALE**  
 0 2 MILES

WASTEWATER TREATMENT DESIGN & PERMITTING  
 SADDLE RANCH SUBDIVISION  
 ROLAND CUTOFF ROAD  
 ROLAND, ARKANSAS

BOUNDARY OFFSETS

JOB NUMBER	FERG-11791
DRAWING NO.	3



ATTACHMENT 1  
GENERAL FACILITY INFORMATION

1. Facility Name: Saddle Ranch Subdivision WWTP

2. Type of Facility: Extended Aeration

3. Population Served:  
Present: 0 Design: 200 Homes

4. Flow:

	Present	Design
Average	0	30,000 gpd
Maximum	0	50,000 gpd
Peak	0	50,000gpd

5. Water Quality:  
Assumed  Actual  Source: \_\_\_\_\_

	Influent:		Effluent:	
BOD5	250	mg/l	10	mg/l
TSS	250	mg/l	10	mg/l
NH3-N	50	mg/l	5	mg/l

Basis for Assumptions, if made:  
Metcalf and Eddy textbook. Past history with wastewater plants.

6. Is the system above the 100-year flood plain? Yes  No

7. List Treatment System:

a. Existing:

- |               |          |
|---------------|----------|
| 1. <u>n/a</u> | 5. _____ |
| 2. _____      | 6. _____ |
| 3. _____      | 7. _____ |
| 4. _____      | 8. _____ |

b. Proposed:

- |   |                                 |
|---|---------------------------------|
| 1. <u>Primary treatment at residences</u> | 5. <u>Clarifiers</u>            |
| 2. <u>EQ chamber</u>                      | 6. <u>Filtration</u>            |
| 3. <u>Sludge holding chamber</u>          | 7. <u>Chlorine disinfection</u> |
| 4. <u>Aeration chamber</u>                | 8. <u>Dechlorination</u>        |

ATTACHMENT 2  
FLOW MEASUREMENT, SCREENING AND GRIT REMOVAL

A. Flow Measurement

1. Type Metering Device: Totalizing meter
2. Location: Influent \_\_\_\_\_ Effluent x
3. Indicating and Recording Mechanism: Gallons

B. Bar Screen

1. Area: Total 5 ft<sup>2</sup>      Effective 3.5 ft<sup>2</sup>.
2. Space Between Bars: 1 inches
3. Velocity: 1 ft/s      4. Slope of Screen: sloped bar screen
5. Is Drainage Platform Provided? Yes       No
6. Method of Cleaning: Manual       Mechanical
7. Mechanical Screen:  
Capacity \_\_\_\_\_ MDG      Type \_\_\_\_\_
8. Auxiliary Bar Screen:    Yes       No

C. Comminutoring Device

1. Location \_\_\_\_\_
2. Size: \_\_\_\_\_ inches    3. Capacity: \_\_\_\_\_ MGD
2. Auxiliary Bar Screen:    Yes       No

D. Grit Chamber

1. No. of Chambers 1
2. Type Gravity
  
3. Cross Section Area:  
Each 4 ft<sup>2</sup>      Total 4 ft<sup>2</sup>      Length 4 ft  
  
Width 1 ft      Diameter \_\_\_\_\_ ft
4. Calculated Velocity of Flow \_\_\_\_\_ ft/s
5. Method of Cleaning:      Manual       Mechanical
6. Surge prevention:      Yes       No
7. Method of Velocity Control Pump
8. Detention Period:  
Present n/a Seconds      Design 400 Seconds
9. Drain Provided:      Yes       No

ATTACHMENT 3  
ACTIVATED SLUDGE

1. Process:

Conventional       Contact Stabilization       Extended Aeration   
Sequence Batch Reactor       Step Aeration       Complete Mix   
Other \_\_\_\_\_

2. Number of Tanks: 1    3. Are all tanks same size? Yes     No

4. Shape of Tank: Rectangle    5. Are waterstops provided? Yes     No

5. Inside Dimensions of Each Tank (ft):

Length 59'-9" Width 11'-11" Depth 11'-0" Diameter \_\_\_\_\_

6. Effective Volume of each Tank: 50,000 gallons

7. Total Tank Volume: 58,593 gallons

8. Recirculation Rate: 0.0375 MGD

9. Design Flow (including recirculation): 0.05 MGD

10. Percentage of Daily Flow of Return Sludge to Tank: 0% - 150%

11. Detention Time: 1440 minutes

12. Aeration Tank Organic Loading: 15.6 lb BOD<sub>5</sub>/day/1000ft<sup>3</sup>

13. F/M Ratio: \_\_\_\_\_ lb BOD<sub>5</sub>/day/ lb MLVSS

14. MLSS: 4500 mg/L Assumed  or Actual

15. MLVSS/MLSS Ratio: 0.74

16. Are the inlets and outlets for each aeration tank suitably equipped to permit controlling the flow to any unit and to maintain reasonably constant liquid levels?

Yes     No

17. Freeboard in Aeration Tanks (minimum 24 inches): 16 inches

18. Is the type of aeration system able to provide the necessary oxygen requirements?

Yes     No

19. Sludge Return Pumps:

Number Pumps: 2 Type: Airlift Capacity Each: 34 to 51 gpm  
Total Capacity: 25 gpm Rated Heads: 15 ft  
Computed Heads: 15 ft

20. Sequence Batch Reactors **Only**:

Cycle Duration: \_\_\_\_\_ minutes Mixing Duration: \_\_\_\_\_ minutes

Low water level: \_\_\_\_\_ ft High water level: \_\_\_\_\_ ft

Hydraulic Retention Time: \_\_\_\_\_ minutes

ATTACHMENT 4  
AERATION SYSTEM

1. Required Air: 288,296 ft<sup>3</sup>/lb BOD<sub>5</sub>/day
2. Furnished Air: 360,000 ft<sup>3</sup>/ lb BOD<sub>5</sub>/day
3. Type of System: Diffused Air  Mechanical

4. Diffused Air Equipment:

Number Blowers 2 Capacity of each 250 ft<sup>3</sup>/m

Total Capacity of Blowers 250 ft<sup>3</sup>/m

Diffusers: Plates  Fixed Tubes  Swing Diffusers   
Impingement Aerator  Jet Aerator

5. Mechanical Aeration Equipment:

Number Units \_\_\_\_\_ Type of Unit \_\_\_\_\_

Capacity of Each Unit \_\_\_\_\_ hP

Operated Intermittently by Clock Time? Yes  No

ATTACHMENT 5  
LAGOONS

1. Type: Controlled Discharge Facultative Lagoon System   
 Flow-Through Facultative Lagoon System   
 Aerated Lagoon System   
 Combination \_\_\_\_\_

2. Number of Ponds: \_\_\_\_\_ 3. Number of Cells per Pond: \_\_\_\_\_

4. Ponds in Series or Parallel Operation: \_\_\_\_\_

5. Pond/Cell Depth (ft):

Pond Number	Maximum	Minimum	Average
1	_____	_____	_____
2	_____	_____	_____
3	_____	_____	_____

6. Freeboard of Each Pond (ft):

Pond 1: \_\_\_\_\_ Pond 2: \_\_\_\_\_ Pond 3: \_\_\_\_\_

7. Pond/Cell Width (ft):

Pond Number	Maximum	Minimum	Average
1	_____	_____	_____
2	_____	_____	_____
3	_____	_____	_____

8. Pond/Cell Length (ft):

Pond Number	Maximum	Minimum	Average
1	_____	_____	_____
2	_____	_____	_____
3	_____	_____	_____

9. Volume of Each Pond/Cell (gallons):

Pond Number	At Maximum Depth	At Minimum Depth	At Average Depth
1	_____	_____	_____
2	_____	_____	_____
3	_____	_____	_____

7. BOD Loading of Each Pond/Cell (mg/l):

Pond Number	Present	Design
1	_____	_____
2	_____	_____
3	_____	_____

8. Retention Time at Average Depth (minutes):

Pond Number	Present	Design
1	_____	_____
2	_____	_____
3	_____	_____

9. Liner Material of Each Pond:

Pond 1: \_\_\_\_\_ Pond 2: \_\_\_\_\_ Pond 3: \_\_\_\_\_

10. If synthetic liner, how is liner attached? Is liner vented?

\_\_\_\_\_

12. How is the bank protected?

\_\_\_\_\_

13. Slope of internal banks: \_\_\_\_\_

14. Outlet

Adjustable: Yes  No  Height above bottom of Pond: \_\_\_\_\_ ft

15. Is lagoon aerated? Yes  No



ATTACHMENT 6  
RECIRCULATING SAND FILTER

1. Type of Pretreatment: \_\_\_\_\_
2. Filter Media:  
Material \_\_\_\_\_ Effective Size \_\_\_\_\_ mm  
Uniformity Coefficient \_\_\_\_\_ Depth \_\_\_\_\_ ft
3. Underdrains:  
Type \_\_\_\_\_ Slope \_\_\_\_\_ Bedding \_\_\_\_\_
4. Hydraulic Loading: \_\_\_\_\_ gpd/ft<sup>2</sup>
5. Organic Loading: \_\_\_\_\_ lb/day/ft<sup>2</sup>
6. Recirculation Ratio: \_\_\_\_\_
7. Recirculation Tanks:  
Volume \_\_\_\_\_ gallons Number of Tanks \_\_\_\_\_
8. Dosing:  
Time On \_\_\_\_\_ minutes Time Off \_\_\_\_\_ minutes  
Frequency \_\_\_\_\_ Volume/orifice \_\_\_\_\_ gallons/orifice

ATTACHMENT 7  
CLARIFIERS

1. Type: Dual Hopper
2. Number of Tanks: 2
3. Surface Dimensions (ft):  
Width 9' Length 18' Diameter 14' High
4. Sidewall Depth: 11'-7" ft
5. Detention Period (minutes):  
At design flow 240 At peak flow 240
6. Overflow Rate (gpd/ft<sup>2</sup>):  
At design flow 308 At peak flow 308
7. Surface Area: 162 ft<sup>2</sup>

ATTACHMENT 8  
SLUDGE TREATMENT

A. Sludge Digestion Tanks

1. Number of Units \_\_\_\_\_ 2. Type \_\_\_\_\_
3. Capacity: \_\_\_\_\_ 4. Single or Two Stage: \_\_\_\_\_
5. Type of Cover: \_\_\_\_\_ 6. Is Tank Insulated? Yes  No
7. Heating (pipe coils): Diameter of Pipes: \_\_\_\_\_ inches  
Total Surface Area: \_\_\_\_\_ ft<sup>2</sup>
8. Heating (heat exchanger): Capacity of unit \_\_\_\_\_
9. Is there a cross connection between the liquor selector flushing line and the drinking water supply? Yes  No
10. Thermometers: Yes  No  11. Flame or Drip Traps: \_\_\_\_\_
12. Waste Burner: Yes  No  13. Manholes in Cover: Yes  No
14. Supernatant Outlets: Yes  No
15. Disposal of Supernatant: \_\_\_\_\_
16. Provisions for Recirculation of Sludge? Yes  No
17. Provisions for Sampling? Yes  No
18. Sludge Removal Lines: Yes  No
19. Explosion Proof switches, fixtures: Yes  No
20. Disposal of Wet Sludge: \_\_\_\_\_

B. Sludge Drying Beds

1. Number Units: \_\_\_\_\_ 2. Required Area: \_\_\_\_\_ ft<sup>2</sup>
3. Area Each Bed: \_\_\_\_\_ ft<sup>2</sup> 4. Total Area: \_\_\_\_\_ ft<sup>2</sup>
4. Area per Capita: Present \_\_\_\_\_ ft<sup>2</sup> Design \_\_\_\_\_ ft<sup>2</sup>

5. Gravel:  
Layer Depths: \_\_\_\_\_ ft, \_\_\_\_\_ ft \_\_\_\_\_ft  
Sizes: \_\_\_\_\_, \_\_\_\_\_, \_\_\_\_\_
6. Sand: Depth \_\_\_\_\_ ft Size \_\_\_\_\_
7. Underdrains: Size \_\_\_\_\_ Spaced \_\_\_\_\_
8. Freeboard above Sand: \_\_\_\_\_ ft
9. Slope of Delivery Pipe: \_\_\_\_\_
10. Suitable Splash Plate: Yes  No
11. Disposal of Sludge Bed Drainage: \_\_\_\_\_
12. Disposal of Dry Sludge: \_\_\_\_\_

ATTACHMENT 9  
DISINFECTION

A. CHLORINATION

1. Type of Chlorination: Tablet  Gas
2. Capacity: 3.34 #/24 hr    3. Location: Prior to outlet
4. Ventilation: Yes  No
5. Point of Application in Process: At the dechlorination chamber
5. Contact Chamber:  
Design Flow 0.05 MGD    Peak Flow 0.05 MGD  
Volume 274 gallons  
  
Inside Dimensions (ft)  
Length 4 Width 2 Depth 4.58 Diameter v  
  
Detention Time 30 minutes    Drain Provided? Yes  No
6. Scum Baffle: Yes  No
7. Point of Application: In the chlorinator

B. ULTRA VIOLET

1. Design Flow : \_\_\_\_\_ MGD    2. Peak Flow: v MGD
3. Number of Channels: \_\_\_\_\_ 4. Number of Banks per Channel: \_\_\_\_\_
5. Space between lamps: \_\_\_\_\_ inches
6. UV Radiation Dosage: \_\_\_\_\_ mW s/cm<sup>2</sup>

ATTACHMENT 10  
FLOW EQUALIZATION

1. Use: Equalization of flow
2. Location in process: Inlet
3. Type: Chamber
4. Shape: Rectangular
5. Dimensions (ft):  
Width 11'-11" Length 9'-6" Diameter \_\_\_\_\_ Depth 11'-0"
6. Effective Volume: 7500 gallons
7. Will excess flow being diverted to the equalization basin undergo preliminary treatment first? Yes  No
8. Is aeration or mechanical equipment used for mixing? Yes  No

ATTACHMENT 11  
PRIMARY SEDIMENTATION

A. Settling Tanks:

1. Type: \_\_\_\_\_ 2. Number of units: \_\_\_\_\_
3. Dimensions: (ft)  
Width \_\_\_\_\_ Length \_\_\_\_\_ Diameter \_\_\_\_\_ Depth \_\_\_\_\_
- Surface Loading: \_\_\_\_\_ gpd/ft<sup>2</sup>
6. Overflow Rate: \_\_\_\_\_ gpd/ ft. weir
7. Design of inlet and outlet baffles: \_\_\_\_\_
8. Design for skimming: \_\_\_\_\_
9. Disposal of scum: \_\_\_\_\_
10. Diameter sludge pipes: \_\_\_\_\_ inches
11. Provision for flushing and draining sludge lines? Yes  No

B. Other:

Describe the type of primary sedimentation provided in detail. Provide pertinent design information and details.

\_\_\_\_\_

ATTACHMENT 12  
TRICKLING FILTERS

A. High Rate:

	First Stage	Second Stage
1. Dimensions (ft):		
Width	_____	_____
Length	_____	_____
Diameter	_____	_____
Depth	_____	_____
2. Area (ft <sup>3</sup> ):	_____	_____
3. Recirculation:		
Ratio	_____	_____
How Controlled?	_____	_____
How Measured?	_____	_____
Where returned?	_____	_____
3. Organic Loading (lb BOD/Ac-ft./day):	_____	_____
5. Hydraulic Loading (Mg/Ac/day):	_____	_____
6. Type of distributor:	_____	_____
7. Dosing Method:	_____	_____
8. Minimum Head On Distributor Arms (ft):	_____	_____
9. Size Filter Rock (inches):	_____	_____
10. Sodium Sulfate Cycle Test	_____	_____
11. Provision for ventilation?	Yes <input type="checkbox"/> No <input type="checkbox"/>	Yes <input type="checkbox"/> No <input type="checkbox"/>
12. Provision for flooding?	Yes <input type="checkbox"/> No <input type="checkbox"/>	Yes <input type="checkbox"/> No <input type="checkbox"/>
13. Filter efficiency, after settling %:	_____	_____



B. Standard Rate:

1. Dimensions (ft):  
Width \_\_\_\_\_ Length \_\_\_\_\_ Diameter \_\_\_\_\_ Depth \_\_\_\_\_
2. Area: \_\_\_\_\_ ft<sup>3</sup>
2. Organic Loading: \_\_\_\_\_ ( lb BOD/Ac-ft./day)
3. Hydraulic Loading: \_\_\_\_\_ (MGD/Ac)
4. Type of distributor: \_\_\_\_\_
5. Dosing Method: \_\_\_\_\_
6. Detention Time in Dosing Tank: \_\_\_\_\_ minutes
7. Is Siphon Capacity Adequate? Yes  No
8. Minimum Head on Distributor Arms: \_\_\_\_\_ ft
9. Size Filter Rock: \_\_\_\_\_ inches
10. Sodium Sulfate Cycle Test: \_\_\_\_\_
11. Provision for Ventilation: Yes  No
12. Provision for flooding: Yes  No
13. Provision for Recirculation: Yes  No

# DESIGN CALCULATIONS

# DESIGN CALCULATION SHEET

## Wastewater Treatment System

50,000GPD Crossroads Subdivision  
Benton, AR

### New Wastewater Treatment System

The wastewater treatment system consist of a 50,000 gallons per day extended aeration system complete with and extended aeration period of 24 hours because of the high strength of the BOD 5. The strength of the influent BOD 5 is based on a value of 250 PPM BOD5. The following is the design data for the new system:

Design Flow Rate = 50,000 Gallons Per Day  
BOD 5 = 250 PPM  
TSS = 250 PPM

### AERATION CHAMBER DESIGN

Aeration chamber Volume = 24 hours retention  
Required Volume = 50,000 GPD/ 24 hours x 24 hours = 50,000 Gallons

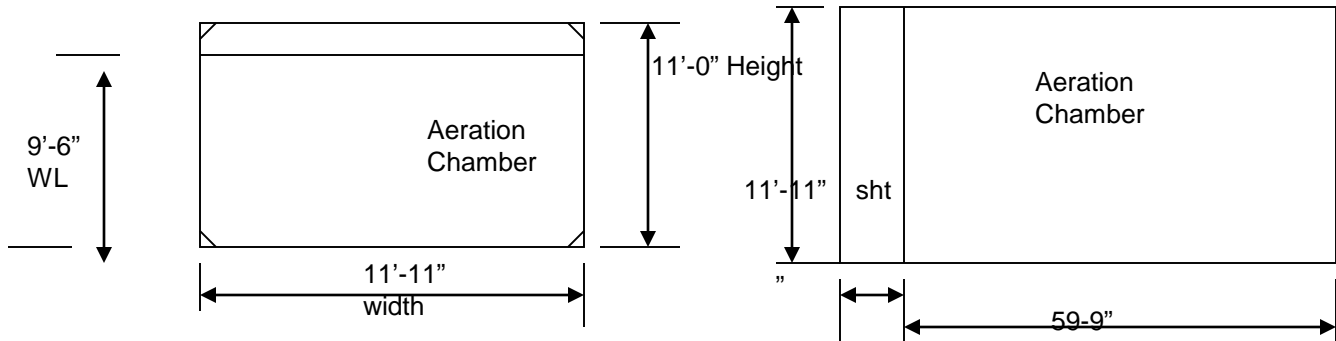

Cross section volume = 11.91' x 9.5' x 7.48 gallons per cubic foot = 846.32 gallons  
Less Fillet Area = 1' x 1' x 7.48 gallons per foot = 7.48 gallons  
Gallons per foot of tank length = 838.84 gallons

Supplied Volume = Length of Tank = 59- 9" ' x 8838 = 50,070.5 gallons OK

### CLARIFIER DESIGN

Clarifier Chamber Volume = 4 hours retention  
Required Volume = 50,000 GPD/ 24 hours x 4 hours = 8,333 Gallons

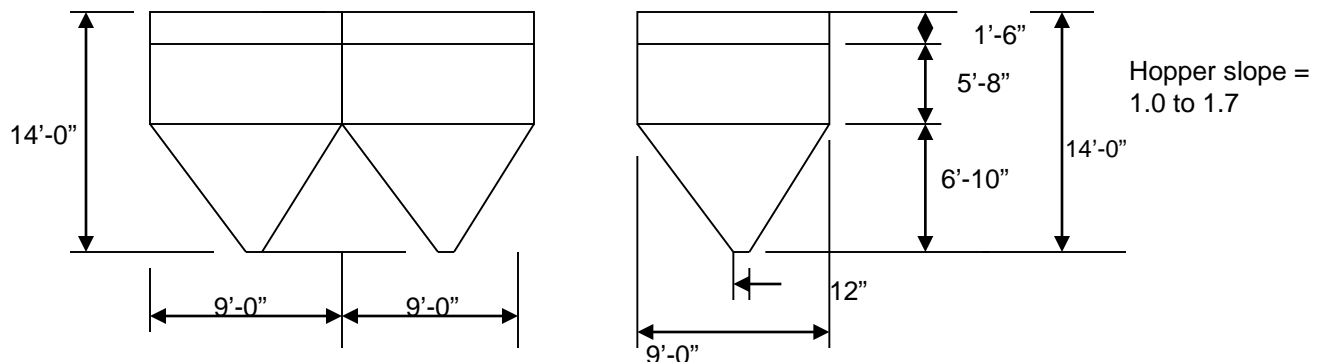

# DESIGN CALCULATION SHEET

## Wastewater Treatment System

50,000GPD Crossroads Subdivision  
Benton, AR

Calculate the clarifier effective 1/3 clarifier hopper volume

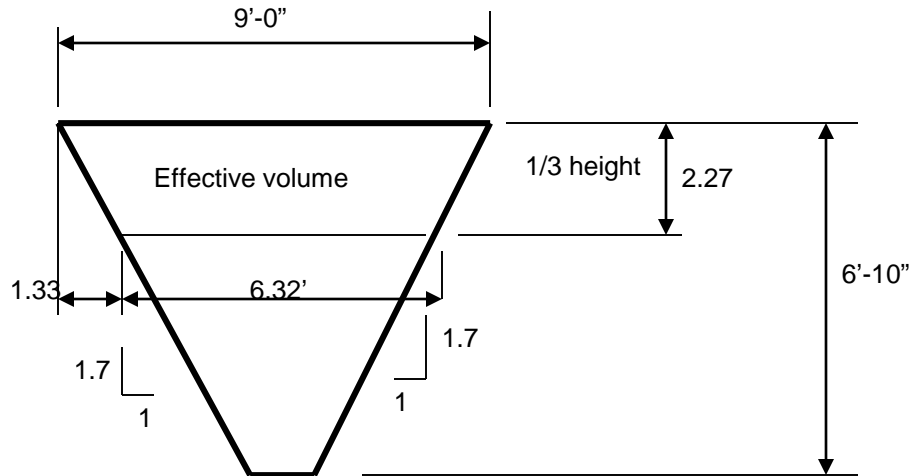

SIDE VIEW

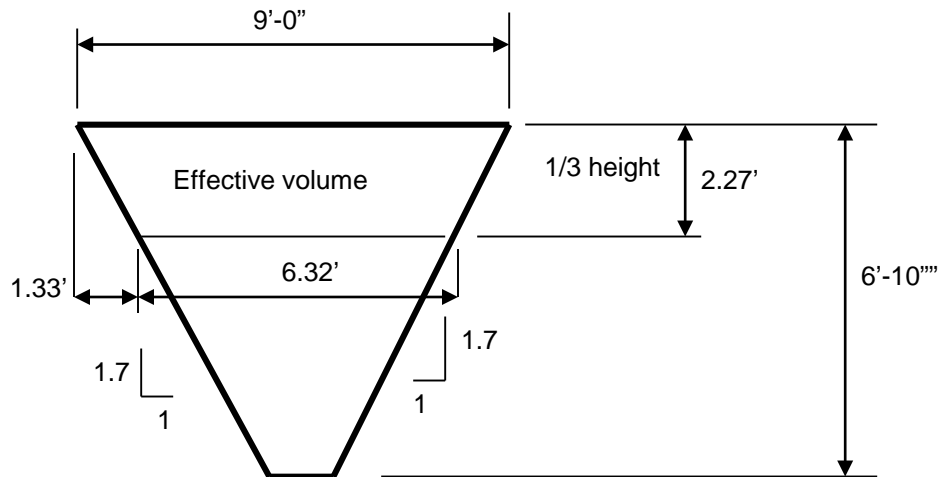

END VIEW

$$\text{Volume of upper 1/3 clarifier chamber} = \frac{AA + BB + \sqrt{AA \times BB}}{3} \times \text{height} =$$

$$= \frac{(9.0 \times 9.0) + (6.32 \times 6.32) + \sqrt{(9.0 \times 9.0) + (6.32 \times 6.32)}}{3} \times 2.27 =$$

$$\frac{81 + 39.9 + 56.8}{3} \times 2.27 / 3 = 178 / 3 = 59.23 \text{ cubic feet}$$

or 59.23 cubic feet x 7.48 gallons per cubic feet = 443 gallons

Volume of upper 1/3 clarifier hopper = 443 gallons

For two hopper volume = 443 gallons x 2 = 886 gallons

# DESIGN CALCULATION SHEET

## Wastewater Treatment System

50,000GPD Crossroads Subdivision  
Benton, AR

Calculate the clarifier side water volume required

$$\begin{aligned} \text{Required clarifier volume} &= 50000 \text{ gallons} / 24 \text{ hour} \times 4 \text{ hour retention} \\ &= 8,333 \text{ gallons} \end{aligned}$$

$$\text{Volume of } 1/3 \text{ hoppers volume of the two hoppers} = 886 \text{ gallons}$$

$$\begin{aligned} \text{Side water volume required} &= 8,333 \text{ gallons} - 886 \text{ gallons} \\ &= 7447 \text{ gallons required} \end{aligned}$$

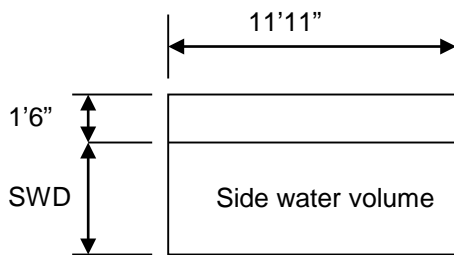

Side View

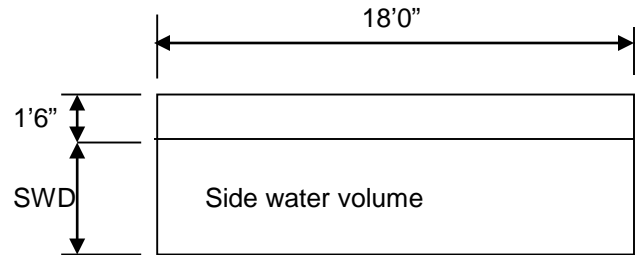

End View

$$\text{SWD Volume} = D' \times 9.0' \times 18.0' \times 7.48 \text{ gallons per foot}$$

$$= 1211 \text{ gallons per foot}$$

$$D = 4948 \text{ gallons} / 1211 \text{ gal per foot} = 4.08 \text{ or } 4' - 1''$$

Calculate the clarifier surface settling rate required

$$\text{Surface area} = 9' - 0' \times 18' = 162 \text{ square feet}$$

$$\text{Surface settling Rate} = 50,000 \text{ GPD} / 162 \text{ square feet}$$

$$= 308 \text{ gallons per day per square foot}$$

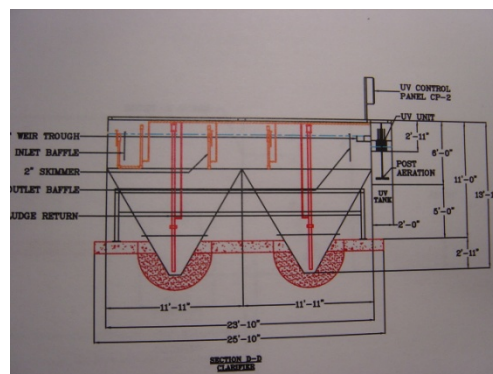

# DESIGN CALCULATION SHEET

## Wastewater Treatment System

50,000GPD Crossroads Subdivision  
Benton, AR

### SECONDARY WASTEWATER TREATMENT

The objective of this SECONDARY wastewater treatment system is to remove a high % of BOD5 and TSS from the wastewater stream. Secondary wastewater treatment proposed to accomplish this is the TIPTON WWTS by utilizing a the extended aeration process a form of the activated sludge process, The extended aeration process combines biological and physical treatment methods with the objectives of oxidizing the BOD and solids, therefore removing the solids and stabilizing the organic matter contained in the raw sewage. In general, organic matter (typically measured as Biochemical Oxygen Demand and referred to as substrate or food), and nutrients in the raw sewage are utilized by microorganisms (e.g. bacteria) to grow and reproduce into a settleable cellular mass. The extended aeration process involves the removal of organic matter using suspended biological growth under aerobic conditions (accomplished in an aeration zone). The term "activated" refers to the microbial mass formed by the process, which serves to stabilize ( or consume) the waste.



The proposed wastewater treatment system shall be designed and manufactured at the Tipton Environmental International, Inc factory located in Batavia, Ohio and shipped to the project site for re-assembly and installation. Once the tank structure has been set into position and made water tight the blowers and controls are set as shown below.



# DESIGN CALCULATION SHEET

## Wastewater Treatment System

50,000GPD Crossroads Subdivision  
Benton, AR

### DESIGN STAGES

The reduction of total BOD by this system shall be in stages which are:

- Primary Screening by the Coarse Bar Screen
- Grit Removal
- Flow Control
- Aeration Zone
- Clarifier Zone
- Sludge Holding Zone
- Post Aeration
- Disinfection Zone Using UV

### BIOLOGICAL PROCESS DESIGN

The following organic loading:

#### Determine pound of BOD5

Pound Of BOD5 = 50000 Gallon/day x 250 #/ 1,000,000 # x 8.33 #/ gallon  
= pound of BOD5  
= 104 pounds of BOD5

Volume Required= 1500 cubic feet per pound of BOD5  
= 156,000 cubic feet

or

= 156,000cubic feet / 7.48 gallons per cubic feet  
= 20855 gallons

Supplied = 50,000 gallons OK

#### Determine Air Required for BOD5

Air Required = 2500 scfm per pound of BOD5  
= 2500 scfm x 104 # = 260000 scfm per day to oxide BOD5  
Operating Continuously  
or = 180 SCFM per minute

#### Determine Air Required for airlifts

Each airlift Requires 10 scfm  
Five Airlift supplied = 10 scfm x 5 = 50 scfm

Total Air Required = 180 + 50 scfm = 230 SCFM

Supplied = 250 SCFM (each blower)

# DESIGN CALCULATION SHEET

## Wastewater Treatment System

50,000GPD Crossroads Subdivision  
Benton, AR

### AIR SUPPLY AND ELECTRICAL CONTROLS

For supplying the air to the extended aeration system dual blower motor units shall be supplied, each with the capacity of 250 SCFM @ 5 PSI. Each provided with a sound reduction enclosure. Time clock controls shall be provided.

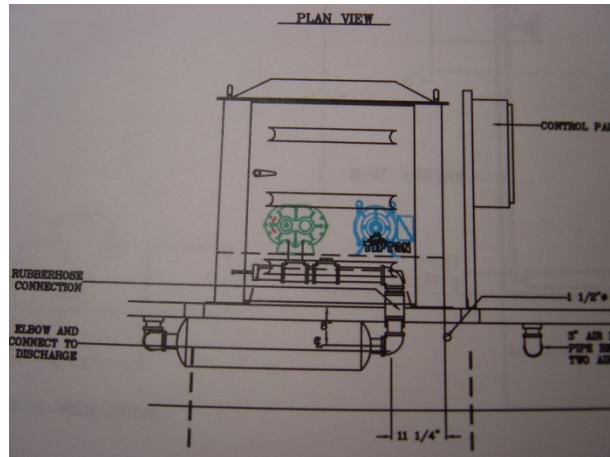



# DESIGN CALCULATION SHEET

## Wastewater Treatment System

50,000GPD Crossroads Subdivision  
Benton, AR

### SLUDGE HOLDING FACILITIES

For solids control, a sludge holding chamber shall be provided. The sludge holding chamber shall be of the aerated type. The volume of the sludge holding chamber shall be 7500 gallons. A supernatant shall be supplied to concentrate the solids in the chamber with the overflow back to the aeration chamber.

### ELECTRICAL CONTROL CONSOLE

An electrical control console shall be provided to operate the dual blower units, the ultraviolet disinfection system and the flow meter. The main blowers shall be programmed by timers and shall operate by an alternator. The main power to the unit shall be 230 volt, three phase, 60 Hz.

# DESIGN CALCULATION SHEET

## Wastewater Treatment System

50,000GPD Crossroads Subdivision  
Benton, AR

### Tertiary Treatment System

Design Flow = 50,000 gallons per day or 50000 gpd/ 1440 minute per day = 34.7 gallons per minute

The Tertiary Filter to have two cells with the capacity of passing the design flow rate of 1 gallon per minute for the two cells.

Area required = 34.7 gallons per minute / 2 cells = 17.35 gallon per minute per cell or  
17.35 square feet per cell.

Supplied two cells equal to 4'-6" wide x 4'-0" long or 18.0 square feet

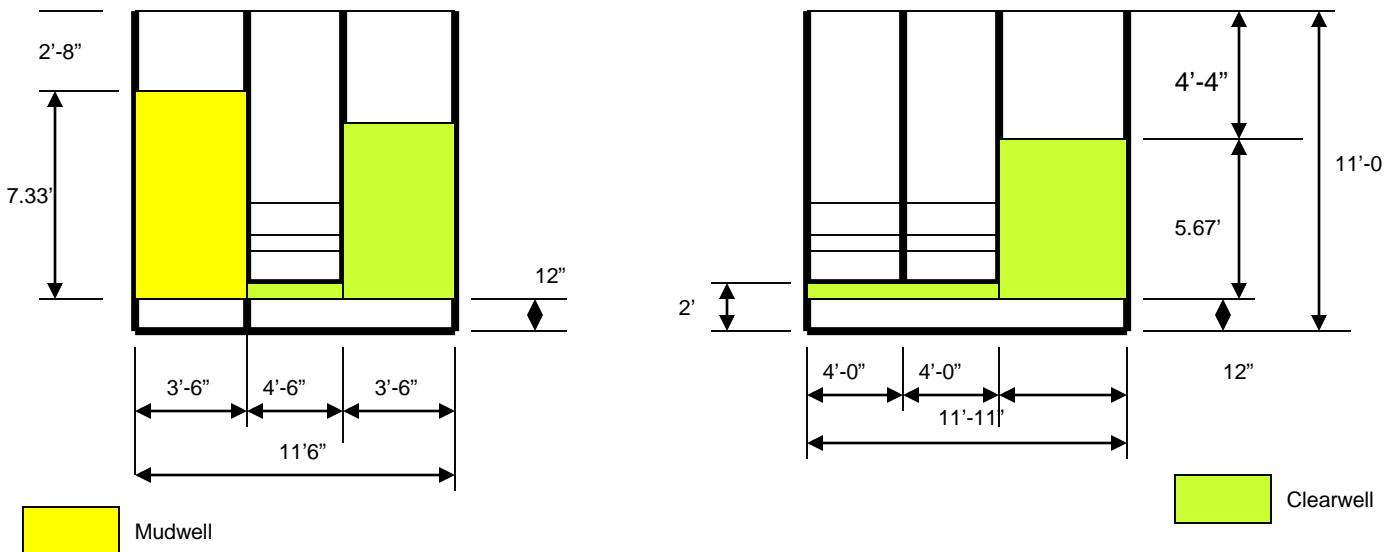

Clear well Volume

$$\text{Total Area} = 11.91 \times 5.67' \times 7.0' = 472.7 \text{ cu ft}$$

$$\text{Less filter area} = 7' \times 4.5' \times 4.67 = 147.10 \text{ cu ft}$$

$$\text{Volume of area less filter area} = 472.7 - 147.1 = 325.6 \text{ cu ft or } 325.6 \times 7.48 = 2435 \text{ gallons}$$

$$\text{Required Volume} = 15 \text{ gpm} \times 17.35 \times 5 \times 2 = 2602.5 \text{ gallons OK}$$

Mudwell Volume

$$\text{Total Area} = 11.91 \times 7.33' \times 3.5' = 291.79 \text{ cu ft}$$

$$\text{Volume of area less filter area} = 291.79 \times 7.48 = 2182 \text{ gallons}$$

$$\text{Required Volume} = 15 \text{ gpm} \times 13.125 \times 5 \times 2 \times 1.1 = 2166 \text{ gallons OK}$$

# EQUIPMENT SPECIFICATIONS

---

# TEII Systems Specifications Sheet

Date: 05-16-2018

Average Design Flow: 50,000 GPD @ 240 PPM BOD5

Manufacturer: Tipton Environmental International, Inc

Location of Project: Pulaski County, Arkansas

Project Engineer: White-Daters & Associates, Inc.

---

## TIPTON ENVIRONMENTAL INTERNATIONAL, INC. PACKAGED BIOLOGICAL WASTEWATER TREATMENT SYSTEM EQUIPMENT SPECIFICATIONS

### Wastewater Treatment System Prefabricated Steel Construction

#### 10 GENERAL

- 1.1 The contractor shall furnish and install one package biological wastewater treatment system, complete and ready for operation in accordance with the plans and specifications stated herein. The treatment system shall include one (1) Model TEII500-FETC prefabricated steel Tipton Environmental International, Inc. using "ASCO2RT" Process, oxygen-controlled reactor system in conjunction with extended aeration process wastewater treatment system complete with secondary treatment as manufactured by Tipton Environmental International, Inc. Batavia, Ohio, U.S.A. The wastewater treatment system will have a total design flow of 50,000 gallons per day. The aeration chamber shall be over-sized for a volume of 50,000 gallons of volume complete with a dual hopper clarifier for an oversized settling area. The proposed equipment package shall include the necessary tank vessels, internal piping, valving, weirs, baffles and all items of equipment as listed below. The secondary treatment system shall be complete with a flow proportioning, flow equalization system, aeration chamber, dual hopper type clarifier, sludge holding tank. For the secondary treatment process. For tertiary treatment a dual cell rapid sand tertiary filter system shall be provided, complete with clearwell chamber, mudwell chamber, disinfection system complete with chlorination, contact tanks and all necessary tank vessels and component equipment necessary for efficient and proper plant operation.
- 1.2 The package system shall be factory prefabricated and assembled, so far as possible, taking into consideration shipping and erection limitations. Because of the total system length, the tankage shall be shipped to the project site in three major tanks pieces. In addition, all internal tank piping and wiring shall be supplied and ended at the appropriate joints whereas the field contractor shall reconnect. All vessel surfaces shall be factory painted as described below.
- 1.3 The basic equipment furnished by the manufacturer shall include, but not be limited to tanks vessels, those vessels being factory painted, all tank internal piping and valving, blower motor unit assemblies, service walkways, and electrical equipment including all internal system wiring and/or controls.

#### 1.5 THE GENERAL CONTRACTORS FIELD SERVICES

The General Contractor shall perform the actual installation of the TEII wastewater water treatment system. The following is a brief description of the general contractor's responsibilities regarding the installation:

---

## TEI Systems Specifications Sheet

Date: 05-16-2018

Average Design Flow: 50,000 GPD @ 240 PPM BOD5

Manufacturer: Tipton Environmental International, Inc

Location of Project: Pulaski County, Arkansas

Project Engineer: White-Daters & Associates, Inc.

---

- A. Provide a crane and other equipment for off-loading and setting of the wastewater treatment system, which come in several major sections and for setting it onto its foundation pad. Attach the anchoring facilities to be positioned in the foundation pad as defined by the contract drawings.
- B. Once the system has been set into position, it shall be reconnected including field welding and or re-assembly the sections which has been disconnected for shipping such as the piping, valving, grating, handrails and wiring which may have been disconnected at the factory for shipping purposes.
- C. The general contractor's electrical field crew shall install at the location shown on the drawings the electrical consoles such as; Model CP-1 (Main Control Panel), CP-2A & CP-2B (flow equalization control panels for blowers and surge pumps), CP-3 tertiary control panel. In addition, they shall run the electrical wiring and conduit to the appropriate ancillary components within the wastewater treatment structure.
- D. All areas requiring touch up painting shall be painted by the Contractors field crew. The areas which will require field welding, shall be not painted, but shall have a taped area over the metal so that field welding can be performed without burning through the paint.
- E. An adequate access road to the plant site shall be provided to enable the lowboy trucks into the project site and for off-loading.
- F. The freight for shipping the unit from Manchester, Tennessee to the project site shall be provided by the equipment manufacture.
- G. Provide facilities and crane for off-loading and setting of the wastewater treatment system onto its concrete foundation pad. It is recommended that the crane size should be a minimum of 100 ton. Access into the site and exit from the site shall be the responsibility of the owner. A two-hour time window schedule to off load each tank has been included. It will be necessary to hold to this time schedule so that the owner is not charged detention time by the freight hauler.
- H. All site utilities to the system shall be tied-in to the system. The electrical power requirements shall be provided at each power block of each control console. The main power to the wastewater treatment system shall be supplied through an electrical power meter, main disconnect, and disconnect for each of the sub-panels — CP-1, CP-2A & B, and CP-3. These disconnects shall be supplied by the owner's field electrical contractor. Each of the sub-panels shall be supplied with a power block to receive the electrical power from these disconnects. The power shall be 480 volts, 3 phase, 60 Hz. A total of four sub-panels, CP-1, CP-2A & CP-2B, CP-3. The necessary control voltage of 120 volt, 1 phase for the ancillary equipment shall be obtained through transformers.
- I. The foundation pad for setting the system in to position within is to be furnished by the field contractor.
- J. Finish grade and placement of gravel and concrete grout around the hopper caps of the clarifier.

---

## TEII Systems Specifications Sheet

Date: 05-16-2018

Average Design Flow: 50,000 GPD @ 240 PPM BOD5

Manufacturer: Tipton Environmental International, Inc

Location of Project: Pulaski County, Arkansas

Project Engineer: White-Daters & Associates, Inc.

---

- K. Field welding the tank structure to a watertight structure shall be by the field contractor. The tank structure shall be shipped in three (3) major tank sections and field welded together per the contract drawings.

### 2.0 SYSTEM DESIGN CRITERIA AND PARAMETERS

- 2.1 The wastewater treatment system will have a total design flow of 50000 gallons per day of domestic wastewater. The aeration chamber shall be sized for a volume of 50,000 gallons of volume. The peak hourly flow rates shall be controlled by the flow equalization system to reduce and maintain the influent flow rate to the average daily flow rate:

- 2.2 Flow Equalization Criteria

- A) Holding Volume = 7,500 gallons
- B) Air line connection to main air header for emergency air supply
- C) Air Supplied = One (1) blowers at 75 SCFM at 5 psi each
- D) Dimensions = 11'-11" wide x 11'-0" high x 9'-6" long
- E) Airline connection to main air headed with shut off valve.
- F) Invert location at side wall of chamber (Invert 1'-4" from top tank)
- G) Sub merged bar screen

- 2.3 Aeration Chamber Criteria

- A) Holding Volume = 50,000 gallons
- B) Air Supplied = two (2) blowers at 250 SCFM @ 5 psi each
- C) Dimensions = 11'-11" wide x 11'-0" high x 59'-9" long
- D) Controlled by time clock

- 2.4 Sludge Holding Criteria

- A) Holding Volume = 4,000 gallons
- B) Air Supplied = from main blower units
- C) Dimensions = 11'-11" wide x 11'-0" high x 4'-10" long

- 2.6 Clarifier Criteria

- A) Holding Volume = 8,833 gallons
- B) Air Supplied = from main blower units
- C) Dimensions = 9'-0" wide x 14'-0" high x 18'-0" long

- 2.7 Tertiary Treatment Criteria

- A) Rapid sand type with dual filter cells
- B) Each Filter Cell Area = 17.5 square feet
- C) Backwash Rate = 15 GPM per square feet = 260 GPM
- D) Clear Well Volume = 2600 Gallons
- E) Mudwell Volume = 2700 Gallons

- 2.8 Disinfection Criteria

---

## TEII Systems Specifications Sheet

Date: 05-16-2018

Average Design Flow: 50,000 GPD @ 240 PPM BOD5

Manufacturer: Tipton Environmental International, Inc

Location of Project: Pulaski County, Arkansas

Project Engineer: White-Daters & Associates, Inc.

---

- A) Disinfection by tablet type chlorinator disinfection unit
- B) Chlorine contact tank Volume = 30 minute detention = 1042 gallons

### 3.0 VESSEL TANK CONSTRUCTION

- 3.1 All tank vessels shall be fabricated of one-fourth inch structural grade steel plated; joined by arc welding with fillets of adequate section for the joint involved. All walls shall be continuous and watertight and shall be supported by structural reinforcing members where required. Fabrication and erection shall conform to the standard fabrication procedures of Tipton Environmental International, Inc in the manufacturing of this tankage and its ancillary equipment. All tankage will have reinforcing members as required. All other areas such as the floor, end walls, and internal bulkheads to be adequately reinforced.
- 3.2 All piping and valving shall be provided constructed of a minimum of schedule 40 steel pipe. The painting of this pipe and valving to be as defined in section below:
- 3.3 The package wastewater treatment system shall be transported to the project site on low boy truck in three major sections plus the hopper caps of the clarifier, which shall be shipped inside the aeration zone. The contractor shall be responsible for field assembly, including field welding and bolting where required.

### 4.0 PAINTING AND CORROSION CONTROL

- 4.1 All tank vessel surfaces to be painted shall be properly prepared in a workmanlike manner to obtain a smooth, clean, and dry surface. All rust, metals fragments, dust, weld slag, and mill scale as well as extraneous matter, and shall be removed by means of cleaning by general methods.
- 4.2 All interior tank vessel surfaces below the main box beam shall be painted with Tnemec 46-465 coal tar paint, or equal to a minimum total dry film thickness of 8-10 mils.
- 4.3 All exterior tank vessel surfaces including the box beam shall be painted with Tnemec 46-465 coal tar paint, or equal to a minimum total dry film thickness of 8 -10 mils.
- 4.4 All steel piping & valving shall be painted with Tnemec 46-465 coal tar paint, or equal to a minimum total dry film thickness of 8 - 10 mils.

### 5.0 FOUNDATION

- 5.1 A concrete foundation pad shall be constructed conforming to the project specifications for level and flatness as specified by the manufacturer on the foundation drawing. The clarifier hopper cap shall penetrate the foundation pad. The concrete contractor shall be responsible for placing these cutouts in the concrete pad. Once the tankages have been set into position the owner's contractor shall be responsible for placing the concrete grout into the cutouts in the foundation pad where the clarifier hopper cap penetrates the pad.

---

# TEII Systems Specifications Sheet

Date: 05-16-2018

Average Design Flow: 50,000 GPD @ 240 PPM BOD5

Manufacturer: Tipton Environmental International, Inc

Location of Project: Pulaski County, Arkansas

Project Engineer: White-Daters & Associates, Inc.

---

## EQUIPMENT SECTION

### FLOW EQUALIZATION EQUIPMENT SECTION

#### DIVISION 6 - FLOW EQUALIZATION SYSTEM

- 6.1 To control the peak hourly flow rates of 7,500 gallons per day of domestic wastewater from homes in subdivision. A flow equalization system shall be provided at the influent end of the wastewater treatment system. The influent peak flow rates shall enter into the flow equalization system where it is held and aerated until the secondary treatment system is ready to process it. Once the influent has been received by the flow equalization chamber it shall be processed by dual flow equalization pumps, pumping it to the flow-proportioning chamber. This chamber shall be so designed that it will allow the average daily flow to be processed and pass through the chamber into the aeration chamber. To control the flow rate from the flow equalization pumps a series of a v-notch weir and a flat weir, which is adjustable, to be provided. The flow equalization control system shall be complete with bar screen, dual flow equalization pumps, liquid level control system, flow proportioning chamber, electrical controls, air blower, coarse air diffuser with air manifold.

Tipton Environmental International, Inc shall provide the following equipment for the flow equalization basin:

- (A) One Flow Equalization Air Blower Unit, 75 SCFM @ 5 psi. The voltage shall be 480 volts, 3 phase, 60 Hz.
- (B) One Flow Equalization Electrical Control Panel Model CP-2B for the surge pumps. The voltage shall be 480 volts, 3 phase, 60 Hz.
- (C) One Flow Equalization Control Panel Model CP-2A for the surge blower unit. The voltage shall be 480 volts, 3 phase, 60 Hz.
- (D) Four Liquid Level Sensors, narrow angle type controlling the surge pumps.
- (D) One Liquid Level Sensor, wide angle type for controlling the surge blower.
- (E) Three Coarse Air Diffusers with drop assemblies complete with air diffusers each with eight diffuser nozzles
- (F) Two Flow equalization pumps P-1, P-2. The voltage 480 volts, 3 phase, 60 Hz.
- (G) One 7,500 gallon flow equalization tank
- (H) One Bar screen mounted in the flow equalization chamber
- (I) One Flow Proportioning Chamber

#### 6.12 INLET CONNECTION

- 6.121 An influent connection to the wastewater system shall be provided. It shall consist of one 6" inlet entering into the flow equalization chamber. The influent shall be discharged into the bar screen.

#### 6.13 Bar Screen



---

## TEII Systems Specifications Sheet

Date: 05-16-2018

Average Design Flow: 50,000 GPD @ 240 PPM BOD5

Manufacturer: Tipton Environmental International, Inc

Location of Project: Pulaski County, Arkansas

Project Engineer: White-Daters & Associates, Inc.

---

6.131 Bar screen shall be provided as shown on the contract drawings located in the flow equalization chamber. Its purpose is to remove any unusually large solids from the incoming crude sewage flow rate. The bar screen shall be fabricated from one-half inch diameter bars spaced one-inch apart and arranged as shown on the drawings. The bars shall be sloped to permit easy cleaning of accumulating debris. A large drying area shall be provided. In addition, a long handle rake shall be provided so that the plant operator can be used to remove the screenings from the bar screen.

### 6.14 AIR SUPPLY FOR FLOW EQUALIZATION TANK

6.141 For supplying the air requirements of the Flow Equalization System control system, one (1) Model BF-75-R33 Blower Motor Units shall be provided as shown on the drawings. The voltage shall be 480 volts, 3 phase, 60 Hz. The unit shall have the capacity of providing 100% of the air requirements for the system. The blower unit shall be installed at the location shown on the drawings. The unit shall be completely factory built and tested before shipping. The blower unit shall be installed within one Fiberglass Enclosure TEII-2 complete with fiberglass hood. The inlet filter silencer, pressure relief valve, pressure gauge, with only the blower discharge rubber hose connection being provided as a single line hook up for the blower. The necessary electrical connection from the blower to CP-2A shall be provided and pre-wired. The enclosure shall have ivory finish. The blower motor enclosure unit shall be mounted on four (4) vibration pad dampers tagged VP-1. This will help reduce blower vibration and noise transmission. The Blower system shall be equipped with one 2" blower discharge pipe with a 2" marine rubber hose with 2 stainless steel clamps.

6.142 The blower unit shall be supplied with each blower unit shall be a Model BF-75-R33-shall be furnished for supplying all the air requirements needed for the flow equalization Basin. The unit shall be capable of delivering 75 SCFM at an operating pressure of 4 psi.

6.143 The blower shall be of the positive displacement type and shall manufactured by Roots Division of Dresser Industries, Inc., Connersville, Indiana or approval equal. The Model number of the blower will be URAI-33 and equipped with a 2" discharge.

6.144 The motor shall be 3 Hp for operation on 480 volt, 3 Phase, 60 Cycle Service, and 1800 RPM. The motor shall be ODP type Model 182 T, E930 7.8 FLA. The wiring to this motor from the control panel shall be provided and installed by the field contractor.

6.145 For determining the blower performance, and/or diffuser condition, a pressure relief valve and pressure gauge. These items shall be pre-mounted and piped within the blower enclosure.

### 6.15 ELECTRICAL CONTROL CONSOLE CP-2A & CP-2B

---

## TEII Systems Specifications Sheet

Date: 05-16-2018

Average Design Flow: 50,000 GPD @ 240 PPM BOD5

Manufacturer: Tipton Environmental International, Inc

Location of Project: Pulaski County, Arkansas

Project Engineer: White-Daters & Associates, Inc.

---

An electrical control center, for the flow equalization system shall be the Model CP2A & CP-2B. Each of these control panels shall both be installed within a NEMA 4 electrical weatherproof enclosure complete with floor mounting facilities installation in the electrical control room as shown on the drawings. The voltage shall be 480 volts, 3 phase, 60 Hz. shall be supplied to each panel at the power block.

A step down transformer shall be supplied to step the electrical power down from 480 volt to 120-volt power for control voltages.

The electrical control center Model CP-2A shall control the operation of the following equipment:

- A) Blower Motor Unit BM-3, 3 HP, the voltage shall be 480 volts, 3 phase, 60 Hz. ODP type Model 182 T, E930 7.8 FLA
- B) Anoxic Mixer MX-1 2, hp, 480 volt, 3 phase, 60 Hz.
- C) Liquid level sensors -1 level sensors wide angle

Flow Equalization Blower Motor Unit - The Flow Equalization blower unit operation shall be controlled by the wide-angle liquid level condition of the flow equalization basin. The blower shall turn on when the on liquid level sensor side is activated on when the water level reach the on level and de-activates when the water level is lowered to the off level.

The electrical control center Model CP-2B shall control the operation of the following equipment:

- A) Flow Equalization Pump No. 1 P-1, 1 1/2 HP, The voltage shall be 480 volts, 3 phase, 60 Hz. 10 FLA
- D) Flow Equalization Pump No. 2 P-2, 1 1/2 HP. The voltage shall be 480 volts, 3 phase, 60 Hz., 10 FLA
- E) Liquid level sensors -4 level sensors narrow angle

Flow Equalization Tank Pumps Control - The Flow Equalization pumps shall operate on a duplex pump alternator operation I mode, where pump one will operate alternately with pump no 1 and 2 on cycles. The pump operation shall be controlled by four (4) encapsulated mercury float Switches (narrow angle) each individually adjustable for the following:

- A) All Pumps off
- B) Lead Pump on
- C) Lag Pump on
- D) High Level Alarm

The Flow Equalization pumps shall operate on a lead-lag with the two pumps alternating. If the liquid level reaches lag pump on level, both pumps shall operate. If the liquid level reaches the high water level, the alarm will be activated.

All wiring, terminal blocks, supports and accessories required for the operations of the control panel shall be provided in compliance with the National Electric Code.

---

## TEII Systems Specifications Sheet

Date: 05-16-2018

Average Design Flow: 50,000 GPD @ 240 PPM BOD5

Manufacturer: Tipton Environmental International, Inc

Location of Project: Pulaski County, Arkansas

Project Engineer: White-Daters & Associates, Inc.

---

D1.3 Flow Equalization Pumps Tagged P-1, P-2, The voltage shall be 480 volts, 3 phase, 60 Hz. The Flow Equalization pumps shall be of the Goulds submersible type. Each pump shall be a 3888D3 Model WS1534D3 as manufactured by Goulds Pump Company. The pump shall have a capacity of 25 GPM @ 15 feet of TDH. The pump shall have a 1 1/2 horsepower motor which will operate on 480 volt, 3 phase, 60 Hz. 10 FLA. Each Flow Equalization pump shall be supplied with a 3-inch discharge.

For easy removal of the flow equalization pumps, a hoist shall be provided adjacent to the pump location.

### 8.0 AERATION CHAMBER

- 8.1 There shall be supplied, an aeration chamber to work in conjunction with the clarifier chambers. The aeration chamber shall conform to the following specifications:
- 8.2 The aeration chamber shall be of sufficient capacity to provide a total volume of the chamber of 50,000 gallons. The vessel shall be so shaped on each side to prevent sludge accumulation, to enhance the rotation of the vessel contents, and to scum and froth accumulation. To insure maximum retention and eliminate short circuiting of minuscule sewage particles, the aeration chamber shall be constructed with air diffusers, placed longitudinally along one side of the chamber so as to, in conjunction with flow control baffles, enhance the spiral rotation of the chamber contents. To ensure adequate circulation velocity, the proportion of the chamber width to depth, in the direction of rotation, shall not exceed 1.33 to 1. The velocity of rotation shall be sufficient to scour the bottom and prevent sludge filleting as well as to prevent the escape to the surface of minuscule air diffusion bubbles and by so causing their entrapment to provide maximum oxygenation efficiency.
- 8.3 An air distribution manifold shall be installed longitudinally on one side of the tank with diffuser drop assemblies 'connected thereto. This manifold shall be designed to create a bank of air to supply the air needs of the system, and other ancillary equipment such as the air diffusers, airlift pumps, and scum skimmer to draw from this bank of air.
- 8.4 Each diffuser drop assembly shall be equipped with an air regulating and/or shutoff valve, a disconnecting union and a diffuser bar with non-clog air diffuser nozzles mounted on the tee bar. The airflow per diffuser shall range from 1 to 5 CFM. This minimum air velocity shall be maintained to insure sufficient velocity for self-cleaning. The diffusers shall be parallel to and near the base of the vessel sidewall and at an elevation, which will provide the optimum diffusion and mixing of the vessel contents. The oxygen transfer capacity of each diffuser shall be such that an adequate supply of oxygen will be maintained in the aeration chamber to meet treatment requirements of the design sewage load. The air diffuser shall be on the air check diaphragm type constructed with a diaphragm mounted on top of the diffuser body. The diffuser body consists of twenty, 3/16" diameter air discharge holes evenly distributed around the diffuser disk. The diffuser will be supplied with standard male pipe thread connections.

---

## TEII Systems Specifications Sheet

Date: 05-16-2018

Average Design Flow: 50,000 GPD @ 240 PPM BOD5

Manufacturer: Tipton Environmental International, Inc

Location of Project: Pulaski County, Arkansas

Project Engineer: White-Daters & Associates, Inc.

---

### 9.0 Clarifier Chamber

- 9.1 There shall be furnished a dual hopper type clarifier chamber to work in conjunction with the aeration chamber of the system. The clarifier chamber shall be of the following dimension:

9'-0" Wide x 18'-0 Long x 11'-7" High

The water level from top of tank to water level = 18"

The clarifier hopper slope to be on a 1 to 1.7 slope

- 9.2 The clarifier chamber shall be of such size as to provide a minimum of four (4) hours retention, equal to 8,833 gallons, based upon the same design flow rate governing the aeration chamber (50,000 GPD), and shall have proper baffling to prevent short circuiting and to provide maximum uniform solids settling area. The clarifier shall be of the two-hopper clarifier type. Settled sludge shall be returned from the clarifier hopper cap floor (sludge well) to the aeration chamber by two positive displacement sludge return systems, consisting of an airlift pump type.

- 9.3 The inlet of the clarifier chamber shall be provided with an influent baffle. Its purpose is to slow the velocity of the flow from the aeration chamber to start the settling process. It shall prevent the floatables from entering the clarifier settling area. A skimmer assembly shall be provided in this zone to remove the floatables and return them back to the aeration zone for additional processing.

- 9.4 The clarifier effluent shall pass over the edge of the baffled adjustable effluent weir plate into the effluent trough and then, out the chamber into the tertiary filter system. The weir plate will be constructed of 1/8" galvanized steel and will be gasketed with 1/8" x 1" neoprene strips.

### 10.0 Airlift Sludge Recirculation System

- 10.1 Installed within the clarifier chamber for returning the settled sludge consisting of two positive sludge re-circulation pump systems. Each clarifier hopper shall be equipped with one, 4" diameter airlift sludge return assembly, meeting the following specifications: The airlift pump system shall have the re-circulation capacity ranging from 0% to 150% of the design flow. The airline supplying air to the pump shall be equipped with an air control valve, which shall vary the capacity of the pump. The airlift pump shall be firmly supported and shall be equipped with a clean-out plug to allow for easy cleaning and maintenance.

### 11.0 Airlift Scum Recirculation System

Installed within the clarifier chamber for controlling and returning to floatables and scum, is a positive scum and skimming re-circulation system. The clarifier shall be equipped with three, 2" diameter airlift skimming device meeting the following specifications: The skimming device shall be of the positive airlift pump type, located in a position to skim and return floating material to the aeration chamber. The air line supplying air to the skimming device shall be equipped with a needle valve to regulate the rate of return. The scum intake shall be equipped with an adjustable assembly, which will enable exact positioning of the skimmer at water level without

---

## TEII Systems Specifications Sheet

Date: 05-16-2018

Average Design Flow: 50,000 GPD @ 240 PPM BOD5

Manufacturer: Tipton Environmental International, Inc

Location of Project: Pulaski County, Arkansas

Project Engineer: White-Daters & Associates, Inc.

---

placing a hand under the water. The discharge port shall be sloped to enable the operator to determine the flow rate.

### 12.0 Air Supply System Secondary Treatment System

- 12.1 For supplying the air requirements of the secondary wastewater treatment system, are two (2), model TEII-250-R47. Each unit shall have the capacity of providing 100% of the air requirements for the system. The two blower units shall be installed within one sound enclosure at the location shown on the drawings. Each blower unit shall be completely factory built and tested before shipping. The blower speed and horsepower has been corrected for this elevation levels at the project site. The main blower units shall be installed within a fiberglass Blower housing TEII-2SN Sound enclosure completes with base and enclosure. The discharge piping of the blowers shall be positioned both within the enclosure and exterior of the enclosure. To help reduce the vibration and the noise being created by the air discharge. The check valve shall all be located at the discharge of the blower. Each blower shall discharge into the air plantum with a discharge rubber hose connection being provide for each blower. The necessary electrical connection from the blower to CP-1 for unit. The enclosure shall have ivory finish. The blower motor enclosure unit shall be mounted on four (4) vibration pad dampers tagged VP-1. This will help reduce blower vibration and noise transmission. The Fiberglass housing shall be equipped with a blower discharge pipe with a marine rubber hose with 2 stainless steel clamps. Each unit shall be completely factory built and tested before shipping.
- 12.2 The blower motor units Model URAI-47 J shall be furnished for supplying all the air requirements needed for the wastewater treatment system. The units shall be capable of delivering 250 SCFM at an operating pressure of 5 psi.
- 12.3 The blower shall be of the positive displacement type and shall be manufactured by Roots Division of Dresser Industries, Inc., Connersville, Indiana or equal Sutorbilt Blower Division Company, Compton, California; or approved equal. The model number of the blower will be URAI-47 J.
- 12.4 The motor shall be 10 HP for operation on 480 Volt, 3 Phase, 60 Cycle Service, and 1800 RPM. The motor shall be explosion proof rated for ODP. The wiring to this motor from the control panel shall be provided and installed by the field contractor.
- 12.5 For determining the blower performance, and/or diffuser condition, a pressure relief valve and pressure gauge. These items shall be premounted and piped at the air plantum.

### 13.0 SECONDARY TREATMENT BLOWER ELECTRICAL CONTROL CONSOLE CP-1

- 13.1 An electrical control center, Model CP-1, shall be installed within a NEMA 4 steel weatherproof enclosure complete with legs installation in the electrical control room as shown on the drawings.

A step down transformer shall be supplied to step the electrical power down fro 480 volt to 110-volt control voltage.

---

## TEII Systems Specifications Sheet

Date: 05-16-2018

Average Design Flow: 50,000 GPD @ 240 PPM BOD5

Manufacturer: Tipton Environmental International, Inc

Location of Project: Pulaski County, Arkansas

Project Engineer: White-Daters & Associates, Inc.

---

The electrical control center shall control the operation of the following equipment:

- A) Blower Motor Unit BM-1, 10 HP. The voltage shall be 480 volts, 3 phase, 60 Hz., ODP, 215 T frame , U 765, 25.6 FLA
- B) Blower Motor Unit BM-2, 10 HP. The voltage shall be 480 volts, 3 phase, 60 Hz., ODP, 215 T frame , U 765, 25.6 FLA

- 13.2 The electrical control center shall control the operation of all the auxiliary component equipment requiring electrical power. The blower motor unit operation time will be intermittent and as controlled by the blower timer. The plant operator shall control the operation time. The necessary selector switches shall be provided to allow either automatic or manual operation of the auxiliary equipment.
- 13.3 The enclosure shall be equal to a NEMA type 4. The electrical controls shall consist of IEC starters, timers, and selector switches necessary. Properly sized circuit breakers or fuses shall protect all electrical equipment and circuitry.
- 13.4 All wire and conduit required between the control panel and the electrical power service should be furnished by and installed by the field controller. The main power supply shall be 480 Volt, 3 Phase, 60 Cycle. Power to the control panel shall be 110 volt, 1 phase. A power block in the control panel shall be supplied for the electrical connection.
- 13.5 The control console shall be a Model CP-1 and shall be completely factory assembled and tested prior to shipment.
- 13.6 Controls shall be mounted to a removable sub-panel within the enclosure and shall be wired and spaced in accordance with the latest National Electric Code.
- 13.7 Blower Operation Controls Method: Each blower for the aeration chamber shall be able to be controlled by the program timer. A selector switch within the control panel shall be used to select the program for automatic operation. The two main blowers for the secondary treatment system shall be controlled by two 24-hour, 7-day time clock and an alternator and shall be capable of being programmed to control the blower run cycle and to adjust both the start set point every 15 minutes on the 24 hour cycle. The clock shall be by Paragon, Model #1015. A selector switch shall be provided with hand off auto for operation selection.

### 14.0 SERVICE WALKWAY

- 14.1 A service walkway shall be provided for service area only to service the plant equipment. Grating panels shall consist of one-piece skid resistant steel plate. All grating panels shall be constructed of 18 gauge, galvanized sheet steel with maximum yield strength of 37,000 psi. Each grating panel has a standard 9-inch surface width, and a 2 1/2-inch rib depth. Furthermore, each panel shall be so supported as to have a safe uniform load carrying capacity of 50 pounds per square foot.

---

## TEII Systems Specifications Sheet

Date: 05-16-2018

Average Design Flow: 50,000 GPD @ 240 PPM BOD5

Manufacturer: Tipton Environmental International, Inc

Location of Project: Pulaski County, Arkansas

Project Engineer: White-Daters & Associates, Inc.

---

- 14.2 A service handrail shall be provided around the perimeter of the service walkway system. The handrail system shall consist of a top rail 1 W aluminum pipe with a center cable guard.

### 15.0 SLUDGE HOLDING CHAMBER

- 15.1 There shall be supplied an aerated sludge holding chamber to work in conjunction with the aeration chamber and clarifier chamber. The aerated sludge holding chamber shall be an integral section of the main system and shall be common to each of the clarifier chambers and shall conform to the following specifications:
- 15.2 The sludge holding chamber shall be of sufficient capacity to provide a total volume minimum chamber volume of 4000 gallons. The vessel shall be so shaped on each side to prevent sludge accumulation, to enhance the rotation of the vessel contents, and to scum. To insure maximum retention and eliminate short circuiting of minuscule sewage particles, the aeration chamber shall be constructed with air diffusers, placed longitudinally along one side of the chamber so as to, in conjunction with flow control baffles, enhance the spiral rotation of the chamber contents. To ensure adequate circulation velocity, the proportion of the chamber width to depth, in the direction of rotation, shall not exceed 1.33 to 1. The velocity of rotation shall be sufficient to scour the bottom and prevent sludge filleting as well as to prevent the escape to the surface of minuscule air diffusion bubbles and by so causing their entrapment to provide maximum oxygenation efficiency.
- 15.3 An air distribution manifold shall be installed longitudinally on one side of the tank with diffuser drop assemblies connected thereto. This manifold shall be designed to create a bank of air to supply the air needs of the system, and other ancillary equipment such as the air diffusers, airlift pumps, and scum skimmer to draw from this bank of air.
- 15.4 Each diffuser drop assembly shall be equipped with an air regulating and/or shutoff valve, a disconnecting union and a diffuser bar with non-clog air diffuser nozzles mounted on the tee bar. The airflow per diffuser shall range from 1 to 5 CFM. This minimum air velocity shall be maintained to insure sufficient velocity for self-cleaning. The diffusers shall be parallel to and near the base of the vessel sidewall and at an elevation, which will provide the optimum diffusion and mixing of the vessel contents. The oxygen transfer capacity of each diffuser shall be such that an adequate supply of oxygen will be maintained in the aeration chamber to meet treatment requirements of the design sewage load. The air diffuser shall be on the air check diaphragm type constructed with a diaphragm mounted on top of the diffuser body. The diffuser body consists of twenty, 3/16" diameter air discharge holes evenly distributed around the diffuser disc. The diffuser will be supplied with standard male pipe thread connections.
- 15.5 The flows into the sludge holding tank shall be direct from the sludge return pump. The necessary piping and valving shall be supplied to allow the flow to occur manually at the plant operators' requirements.
- 15.6 The supernatant shall be returned to the flow equalization chamber for re-processing and treatment.

---

# TEII Systems Specifications Sheet

Date: 05-16-2018

Average Design Flow: 50,000 GPD @ 240 PPM BOD5

Manufacturer: Tipton Environmental International, Inc

Location of Project: Pulaski County, Arkansas

Project Engineer: White-Daters & Associates, Inc.

---

## TERTIARY FILTER SYSTEM

### 17.0 General

- 17.1 The contractor shall furnish and install one prefabricated steel tertiary filter of the wastewater treatment system, a tertiary filter system. It shall be complete and ready for operation in accordance with the plans and specifications stated herein and furnished and as an integral section of the secondary treatment system. The tertiary treatment system shall be a TEII Model TF-500-C prefabricated steel package unit as manufactured by Tipton Environmental International, Inc. This section of the wastewater treatment system is of the tertiary treatment type, specifically known as rapid sand filter, designed for treating a total of 50,000 gallons per day of 30 PPM-BOD5 domestic sewage based on composite sewage samples of the average daily flow. The complete system includes all necessary equipment for efficient plant operation.
- 17.2 The tertiary filter will be factory assembled, so far as possible, with piping, valving and controls. All surfaces shall be factory painted.

### 18.0 PROCESS AND OPERATING INSTRUCTIONS

- 18.1 Influent Characteristics:

The system is capable of treating 50,000 gallons per day of secondary treat domestic sewage, having an organic strength of 30 PPM 5 day BOD, and 30 PPM suspended solids. The tertiary system is subject to the performance of the secondary treatment system. No substances will be introduced in quantities, which are toxic to biological organisms.

### 19.0 INLET CONNECTION

- 19.1 The influent connection to the tertiary filter system shall consist of a flow trough, receiving flow from the clarifier effluent trough with connections to the feed trough of the filter. In addition, the feed trough shall be equipped with a tertiary by-pass. The filter cells shall be feed to each cell by a splash plate and shut off valve. This connection shall be from the port trough to the tertiary feed trough as shown on the detail drawings. The by-pass shall consist of a pipe plug within the tertiary feed trough.

### 20.0 Filtrate Holding Chamber

- 20.1 Two (2) filtrate holding chambers, each located above the filter media shall be of sufficient capacity and surface area to entrap and hold floating, suspended and Settable solids until such time these solids are returned to the wastewater treatment system during filter media backwash by means of the mudwell and return pumps. The volume of each chamber shall not be less than 100 gallons. Each chamber



---

## TEI Systems Specifications Sheet

Date: 05-16-2018

Average Design Flow: 50,000 GPD @ 240 PPM BOD5

Manufacturer: Tipton Environmental International, Inc

Location of Project: Pulaski County, Arkansas

Project Engineer: White-Daters & Associates, Inc.

---

shall have a minimum water depth of 24 inches above filter media to prevent freezing of filter media.

- 20.2 Means shall be provided in each chamber for manual dumping of the suspended solids into the mudwell. An access and inspection plate shall be provided in the sidewall filtrate holding chamber to allow inspection and maintenance of the filter bed.

### 21.0 Filter Cells

- 21.1 There shall be furnished two (2) filter cells for filtering the flow of the Tertiary Filter System. Each cell shall have not less than 17.36 square feet of filter surface area based on 1 GPM / sq. ft. for each cell. The filter cells shall be located at the bottom of the filtrate holding chamber. Filtrate shall percolate through the filter bed and filter nozzles to the false bottom. The filter nozzles shall be equipped with an air tail pipe. The filter nozzles shall be of the type, which is equipped with an expansion ring, which will allow the nozzle to be installed in the underdrain plate easily. From the false bottom, filtered water shall flow to the clear well chamber. Each filter shall be accessible for inspection and maintenance of the filter media. The filter media shall be shown on the plans and as herein after specified.

### 22.0 Filter Media

- 22.1 Filter media shall be furnished in sealed bags not to exceed 100 pounds each. The filter media shall be packed in a pallet and shipped to the plant site with the filter system. The contractor shall position the filter media in the tertiary filter as shown on
- 22.2 The plans and in the field. The filter media bed shall consist of eight inches (8") of sand, 0.80 to 1.20 MM effective size with a uniform coefficient of 1.4 through 1.7 and twelve inches (12") of anthracite 1.08 MM effective size with a uniform coefficient of

### 23.0 Clear Well

- 23.1 The clear well shall be located as shown on the plans. It shall be so designed so that the filtrate from each of the filter cells can discharge into the clear well from the false bottom underdrain system which is located below the media; then flow through a riser and through the backwash pumps. The clear well shall not have less than 2500 gallons for sufficient volume for backwashing based on two 5-minute backwash cycles. An overflow weir shall be provided for gravity effluent discharge to the disinfection system chamber.

### 24.0 Backwash Pumps

- 24.1 Two (2) backwash pumps shall be furnished and installed in the clear well so as to automatically backwash each filter cell through the water distribution manifolds when required maintaining filtration conditions. Each pump shall be designed to provide one 5-minute backwash at a rate of 15 gallons per minute per square feet, and shall be rated at 270 GPM at 15 TDH. The operating horsepower shall be 2 HP, 480 volt, 60 Hz, 3 phase. Both pumps shall be a Model WS20D4 series 3888D4 with a 4" discharge and shall be manufactured by Goulds Pump Company pumps or approved

---

## TEII Systems Specifications Sheet

Date: 05-16-2018

Average Design Flow: 50,000 GPD @ 240 PPM BOD5

Manufacturer: Tipton Environmental International, Inc

Location of Project: Pulaski County, Arkansas

Project Engineer: White-Daters & Associates, Inc.

---

equal. The backwash rate shall be a minimum of 15 GPM per square foot of filter surface area.

### 25.0 Mud Well Chamber

- 24.1** A mudwell chamber of the tertiary filter system shall be of such size as to handle the total volume of the filtrate backwash. The Volume of this chamber shall not be less than 2800 gallons. A duplex set of pumps shall be provided and installed in the mud well chamber for returning the filtrate backwash liquid to the secondary wastewater treatment. The capacity for each pump shall be 25 GPM at 15' TDH. The operating horsepower shall be 1/2 HP, 480 volt, 60 Cycles, 3 Phase. The pumps shall be a model 3882 and shall be manufactured by or approved equal and have a 2 inch

### UPPLY BLOWER MOTOR UNIT

- 26.1 One (1) positive displacement blower motor unit shall be provided and shall be a Model BF-30-S24 shall be supplied, capable of providing the required CFM for air scouring. The unit shall have the capacity of providing 100% of the air requirements for the tertiary system. The blower unit shall be installed at the location shown on the drawings. The unit shall be completely factory built and tested before shipping. Therefore, the blower speed and horsepower has been corrected for this elevation level. One blower unit shall be installed within a fiberglass Blower housing TEII-2 complete with base and weatherproof hood. The discharge piping of the blower shall be positioned within the housing to help reduce the vibration and the noise being created by the air discharge. The inlet filter silencer, pressure relief valve, pressure gauge, and check valve shall all be located within the housing with only the blower discharge rubber hose connection being provided as a single line hook up for the blower. The necessary electrical connection from the blower to CP-1 shall be provided and pre-wired. The enclosure shall have ivory finish. The blower motor enclosure unit shall be mounted on four (4) vibration pad dampers tagged VP-1. This will help reduce blower vibration and noise transmission. The fiberglass housing shall be equipped with a 2" blower discharge pipe with a 2" marine rubber hose with 2 stainless steel clamps. Each unit shall be completely factory built and tested before shipping.
- 26.2 The blower shall be capable of delivering 30 CFM when operating at 5 PSI. The blower shall be manufactured by Roots Division Dresser Industries, California; or approved equal. The model number of the Sutorbilt blower will be URAI-24.
- 26.3 Each motor shall be 2 Horsepower for operation on 480 volt, 3 Phase, 60 Cycle service 1750 RPM. It shall be of the ODP type. Motor E-929 , 5.6 FLA
- 26.4 Facilities for air scouring the filter media prior to backwash shall be provided. An air distribution system shall be provided under the filter media.

### 27.0 ELECTRICAL CONTROL CONSOLE CP-3

- 27.1 An electrical control center shall be installed within a Nema 4 electrical weatherproof enclosure and shall be provided for mounting as indicated on the plans.

---

## TEI Systems Specifications Sheet

Date: 05-16-2018

Average Design Flow: 50,000 GPD @ 240 PPM BOD5

Manufacturer: Tipton Environmental International, Inc

Location of Project: Pulaski County, Arkansas

Project Engineer: White-Daters & Associates, Inc.

---

27.2 Each filter cell shall be supplied with an AAWS-2 control System. This system shall automatically air scouring and water wash the filter cell. When the resistance of the flow through that filter cell which is caused by the filter media makes the water level in the filtrate collection chamber to rise to a predetermined liquid level, a liquid level control switch shall initiate the automatic air scour cycle. This automatic air and water wash cycle is controlled by a series of adjustable control timers which will allow easy adjustment of each phase of the air and water wash cycles. The AAWS-2 shall include system light which will indicate the operating position of the control system. This light shall be installed within the control panel.

27.3 The enclosure shall be NEMA type 4. The electrical controls shall consist of IEC starters, timers, and switches necessary to automatically control all electrical devices and/or motors on the tertiary treatment system. The blower motor shall be controlled by a H-O-A selector switches and IEC starters. This will be in conjunction with the AAWS-2 control system. Properly sized circuit breakers or fuses shall protect all electrical equipment and circuitry.

27.4 All wire and conduit required between the control panels and the electrical power service shall be furnished and installed by the purchaser

27.5 Wiring and conduit between the control panel CP-3 and the tertiary ancillary equipment as listed below shall be pre-wired and tested at the factory:

- Solenoid Valve For Air Scourer Cell # 1
- Solenoid Valve For Air Scourer Cell # 2
- Solenoid Valve For Clear well aeration

All necessary valving and piping shall also be provided

The main power supply shall be 480 volt, 3 Phase, 60 Cycle, with a control circuit of 120 Volt, 1 Phase, 60 Cycle.

27.6 The electrical equipment, which shall be operated from this control center, are:

- Tertiary Blower Unit BM-4 — 5.6FLA, 480 volt, 3 Phase, 60 Cycle, 145 T,E929
- Backwash Pump P-3 —FLA, 480 volt, 3 Phase, 60 Cycle
- Backwash Pump P-4 —FLA, 480 volt, 3 Phase, 60 Cycle
- Mudwell Pump P-5 — 3.6 FLA, 480 volt, 3 Phase, 60 Cycle
- Mudwell Pump P-6 — 3.6 FLA, 480 volt, 3 Phase, 60 Cycle
- Solenoid Valve For Air Scour Cell # 1
- Solenoid Valve For Air Scour Cell # 2
- Solenoid Valve For Clear well aeration and post aeration

### 28.0 FILTER BY-PASS

28.1 A by-pass shall be supplied to allow manual by-pass of the filter cells. The by-pass shall consist of the necessary flow troughs, flow vanes, etc., to direct either to the filter cells or to the tertiary outlet port.

---

## **TEII Systems Specifications Sheet**

Date: 05-16-2018

Average Design Flow: 50,000 GPD @ 240 PPM BOD5

Manufacturer: Tipton Environmental International, Inc

Location of Project: Pulaski County, Arkansas

Project Engineer: White-Daters & Associates, Inc.

---

- 28.2 The flow distribution trough shall be so designed as to divert the incoming flow proportionally to each filtrate collection chamber. This shall be done by means of diversion vanes.

### **29.0 CLEARWELL AERATION**

- 29.1 An air distribution manifold shall be installed on one side of the tertiary system with diffuser drop assemblies connected thereto. This manifold shall be designed to create a bank of air to supply the air needs of the post aeration system
- 29.2 The diffuser drop assembly shall be equipped with an air regulating valve, a disconnecting union and a diffuser bar with non-clog air diffuser nozzles mounted on the tee bar. This minimum air velocity shall be maintained to insure sufficient velocity for self-cleaning. The diffusers shall be placed as shown on the drawings. The air diffuser shall be on the air check diaphragm type constructed with a diaphragm mounted on top of the diffuser body. The diffuser body consists of twenty, 3/16" diameter air discharge holes evenly distributed around the diffuser disk. The diffuser will be supplied with standard male pipe thread connections.

### **30.0 DISINFECTION CHAMBER**

- 30.1 A chlorine contact chamber shall be provided having a volume of 1042 gallons base and configured as shown on the drawings.
- 30.2 A tablet type chlorination system shall be provided. It shall be a Model 1000 Sanuril
- 30.3 A 90 degree v-notch weir shall be provided for flow measurement within the chlorination contact tank.

### **31 EFFLUENT CONNECTION**

- 31.1 The effluent connection of the tertiary treatment system shall be located as shown on the plans and shall consist of one 6" diameter standard flanged pipe at the location shown.

# WASTEWATER TREATMENT PLANT DRAWINGS

Wastewater Treatment System For  
Saddle Ranch Subdivision  
Pulaski County, Arkansas

Total Design Flow = 50,000 GPD

April 7, 2005  
Revised: August 22, 2005  
Project Number: 2005-054

Owner: ~~Reunion Development, LLC~~  
~~Benton, Arkansas~~ *Saddle Ranch Subdivision - Southwest Equity Investments, LLC*  
*Roland, Arkansas* <sup>1</sup>

Manufacturer: Tipton Environmental  
International, Inc.  
4446 State Route 132  
Batavia, OH 45103  
Phone: (513) 735-2777  
Fax: (513) 735-1485

<sup>1</sup> Title revised from Reunion Subdivision to Saddle Ranch Subdivision. All other drawings are unchanged

<sup>2</sup> Southwest Equity Investments, LLC owns the Tipton Environmental treatment system.



TIPTON  
ENVIRONMENTAL  
INTERNATIONAL, INC.  
4446 STATE ROUTE 132  
BATAVIA, OH 45103  
USA  
WWW.TIPTONENV.COM  
PHONE (513) 735-2777  
FAX (513) 735-1485

DATE	BY	REVISIONS:	DESCRIPTION

PROJECT NAME  
REUNION SUBDIVISION  
Saline County, Arkansas  
Total Design Flow: 50,000 GPD

DRAWING:  
TITLE  
PAGE

PROJECT NO.:  
2005-054

SCALE:  
N1S

DATE:  
8-22-06

DRAWN BY:  
BS

CHECKED BY:  
FDT

APPROVED BY:  
FDT

DWG NO.:  
05-054-01



**TIPTON ENVIRONMENTAL INTERNATIONAL INC.**  
 4446 STATE ROUTE 132  
 BATAVIA, OH 45103  
 USA  
 WWW.TIPTONENV.COM  
 PHONE: (513) 735-2777  
 FAX: (513) 735-1485

REVISIONS:	DESCRIPTION:
DATE:	BY:

**PROJECT NAME:**  
 RE-UNION SUBDIVISION  
 Saline County, Arkansas  
 Total Design Flow= 50,000 GPD

**DRAWING:**  
 PLAN  
 ELEVATION

**PROJECT NO.:**  
 2005-054

**SCALE:**  
 NTS

**DATE:**  
 REVISED  
 6-16-05

**DRAWN BY:**  
 BS

**CHECKED BY:**

**APPROVED BY:**  
 FDT

**DWG NO.:**  
 05-054-02

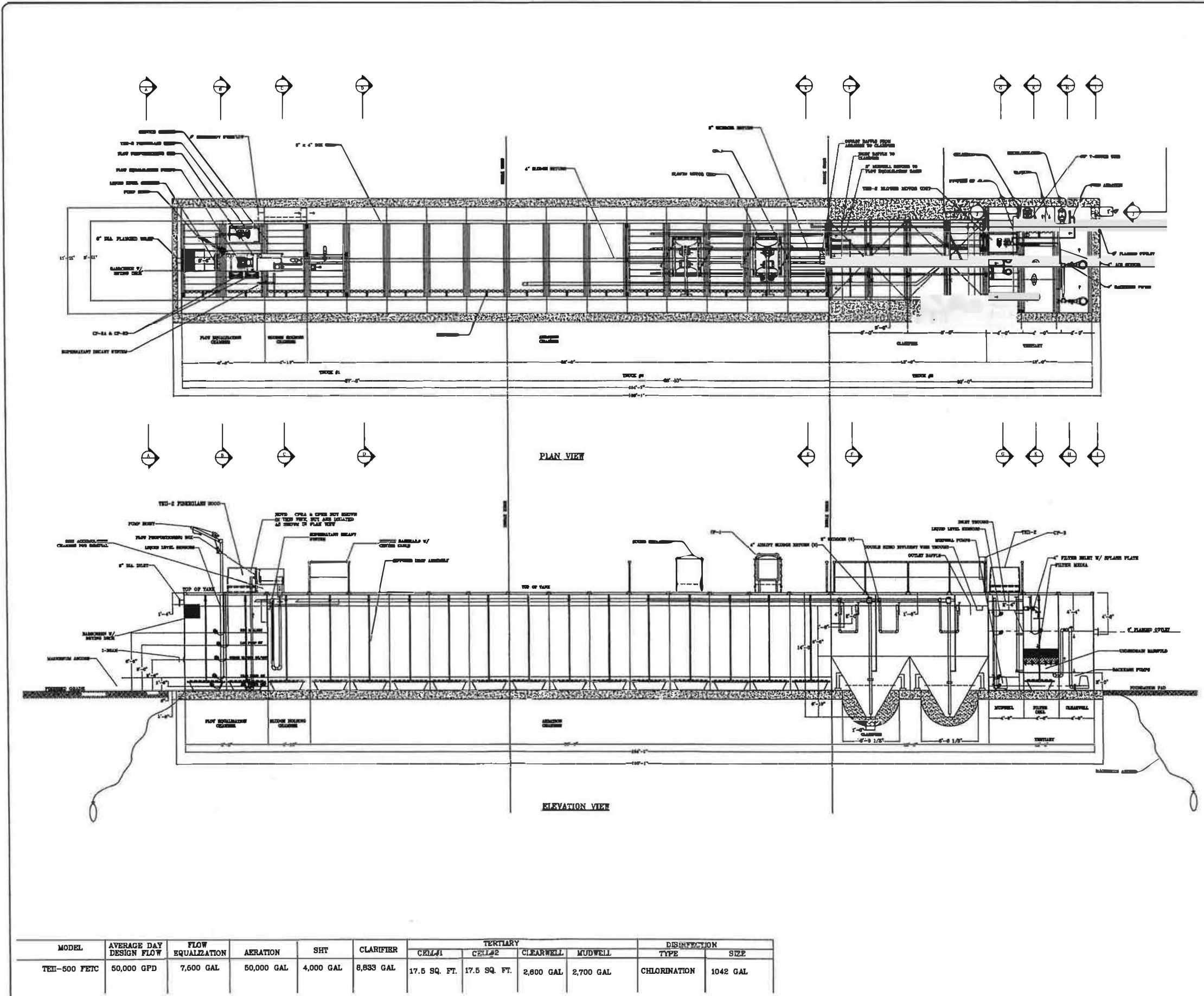

MODEL	AVERAGE DAY DESIGN FLOW	FLOW EQUALIZATION	AERATION	SHT	CLARIFIER	TERTIARY		CLEARWELL	MUDWELL	DISINFECTION	
						CELL#1	CELL#2			TYPE	SIZE
TEX-500 FETC	50,000 GPD	7,600 GAL	50,000 GAL	4,000 GAL	8,833 GAL	17.5 SQ. FT.	17.5 SQ. FT.	2,800 GAL	2,700 GAL	CHLORINATION	1042 GAL

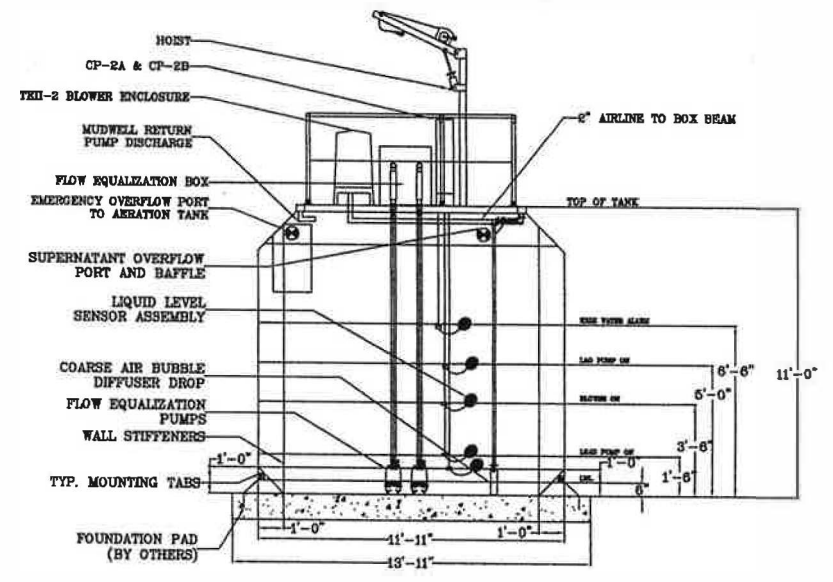
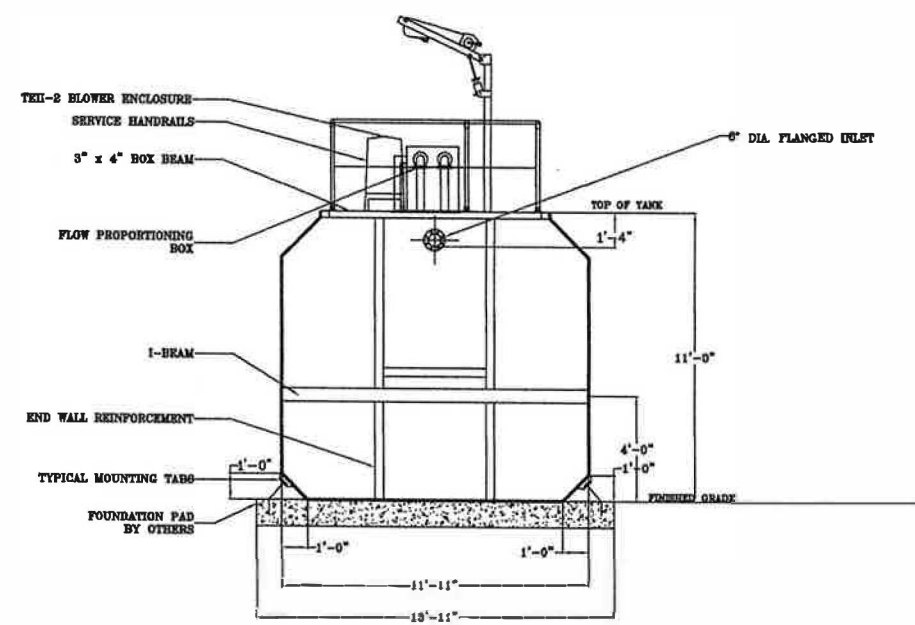
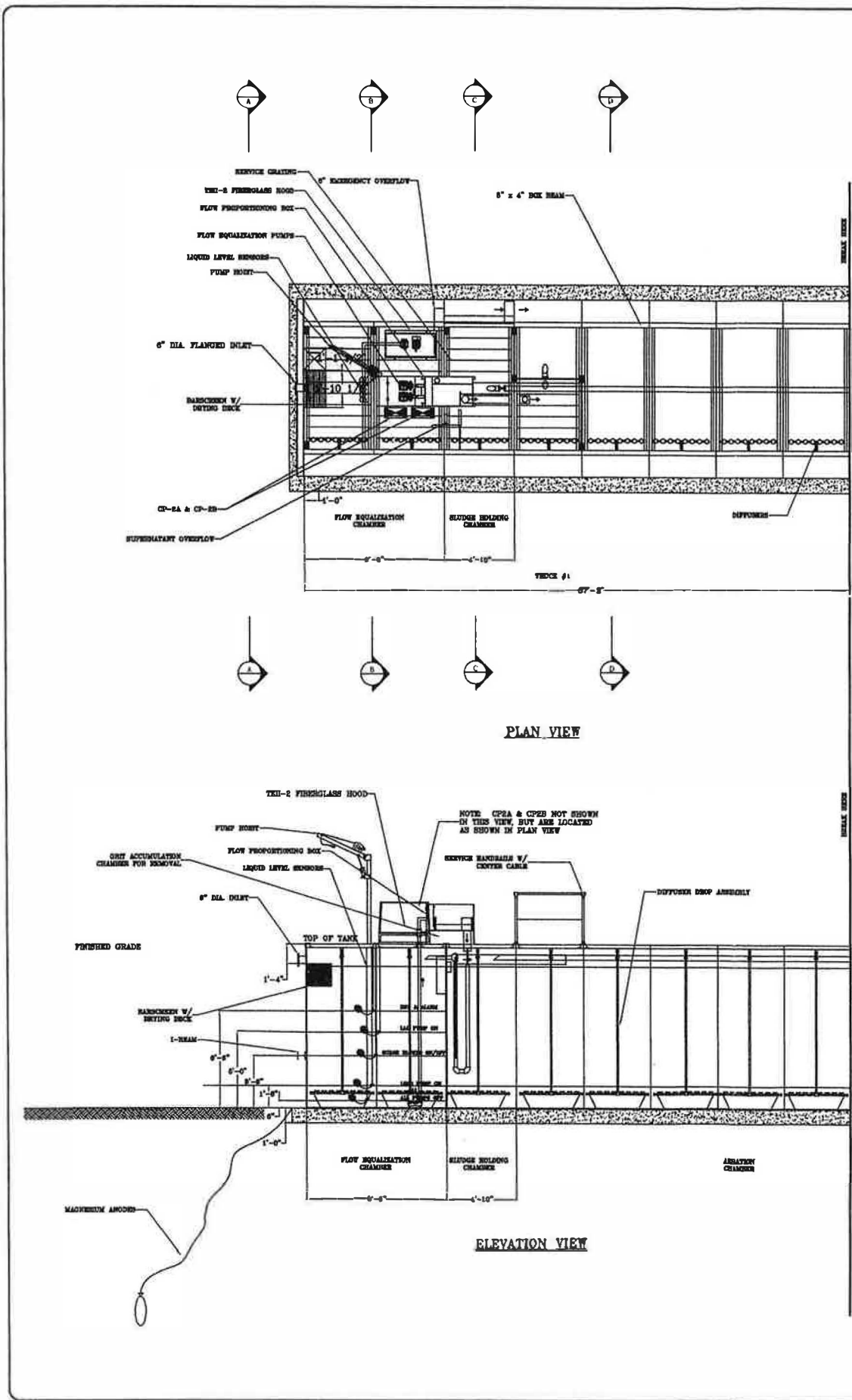

**TIPION ENVIRONMENTAL INTERNATIONAL INC.**  
 4446 STATE ROUTE 132  
 BATAVIA, OH 45103 USA  
 WWW.TIPIONENV.COM  
 PHONE: (513) 735-2777  
 FAX: (513) 735-1485

REVISIONS:	DESCRIPTION:
DATE:	BY:

**PROJECT NAME:**  
 RE-UNION SUBDIVISION  
 Saline County, Arkansas  
 Total Design Flow= 50,000 GPD

**DRAWING:**  
 SECTION VIEW

**PROJECT NO.:**  
 2005-054

**SCALE:**  
 NTS

**DATE:**  
 REVISED  
 6-16-05

**DRAWN BY:**  
 BS

**CHECKED BY:**

**APPROVED BY:**  
 FDT

**DWG NO.:**  
 05-054-03



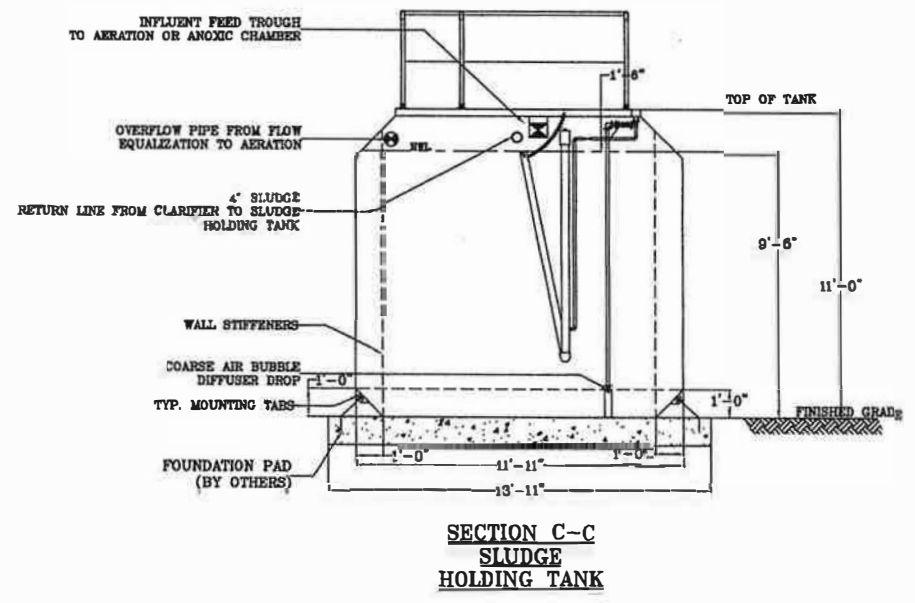
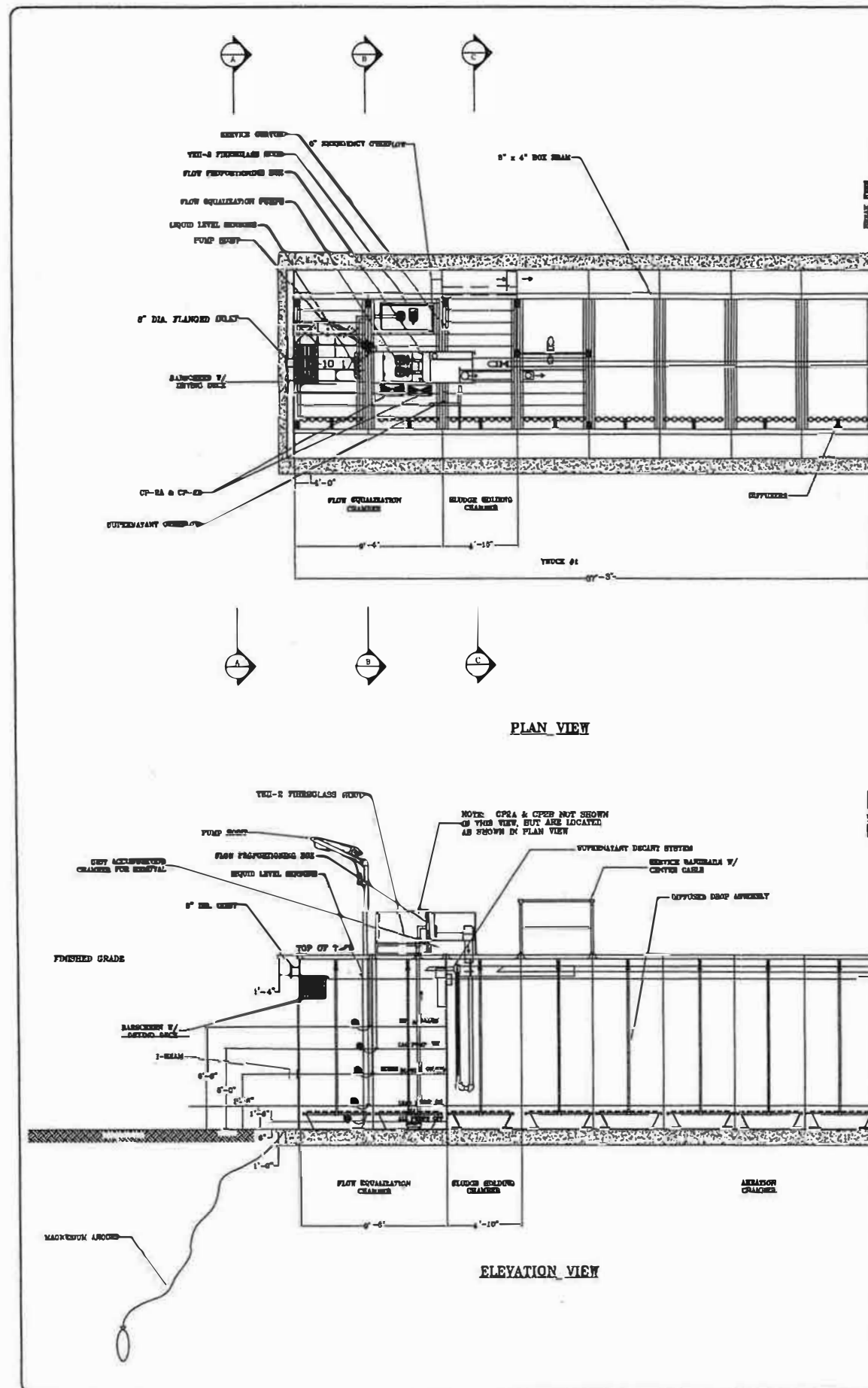

  
**TIPTON ENVIRONMENTAL INTERNATIONAL INC.**  
 4445 STATE ROUTE 132  
 BATAVIA, OH 45103  
 USA  
 WWW.TIPTONENV.COM  
 PHONE: (615) 735-2777  
 FAX: (615) 735-1485

DATE	REV.	DESCRIPTION

**PROJECT NAME:**  
 RE-UNION SUBDIVISION  
 Saline County, Arkansas  
 Total Design Flow = 50,000 GPD

**DRAWING:**  
 SECTION VIEW

**PROJECT NO.:**  
 2005-054

**SCALE:**  
 NTS

**DATE:**  
 REVISED  
 6-16-05

**DRAWN BY:**  
 BS

**CHECKED BY:**

**APPROVED BY:**  
 FDT

**DWG NO.:**  
 05-054-04

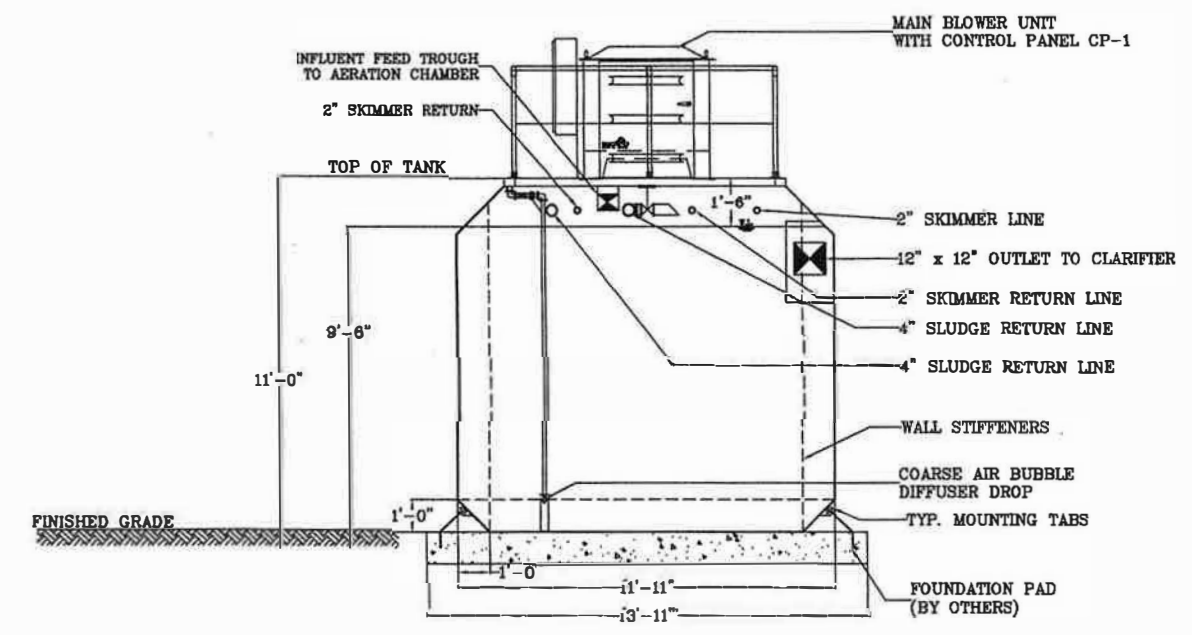
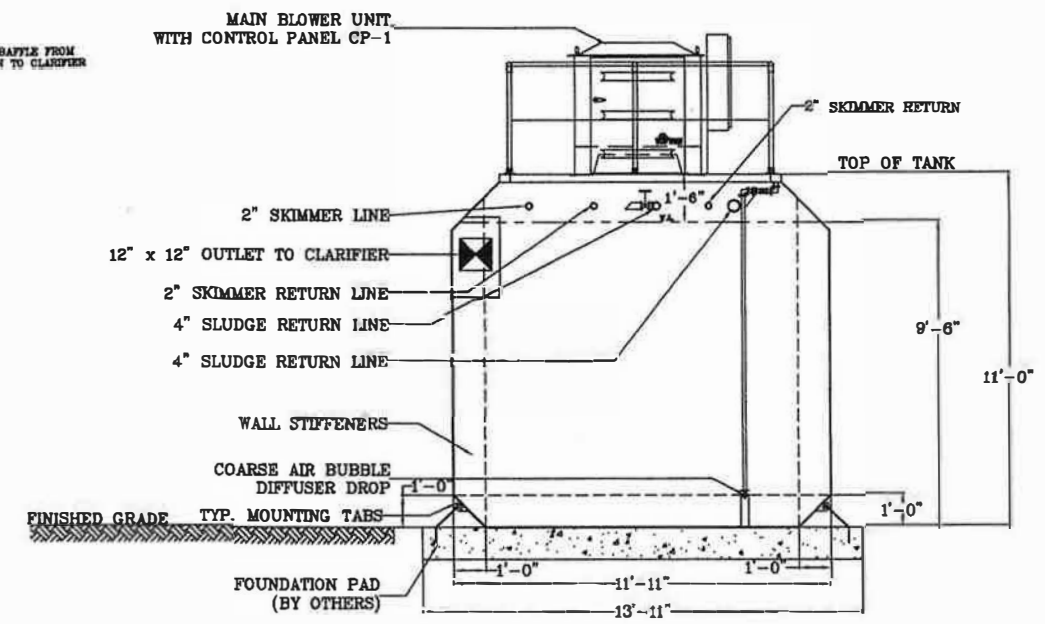
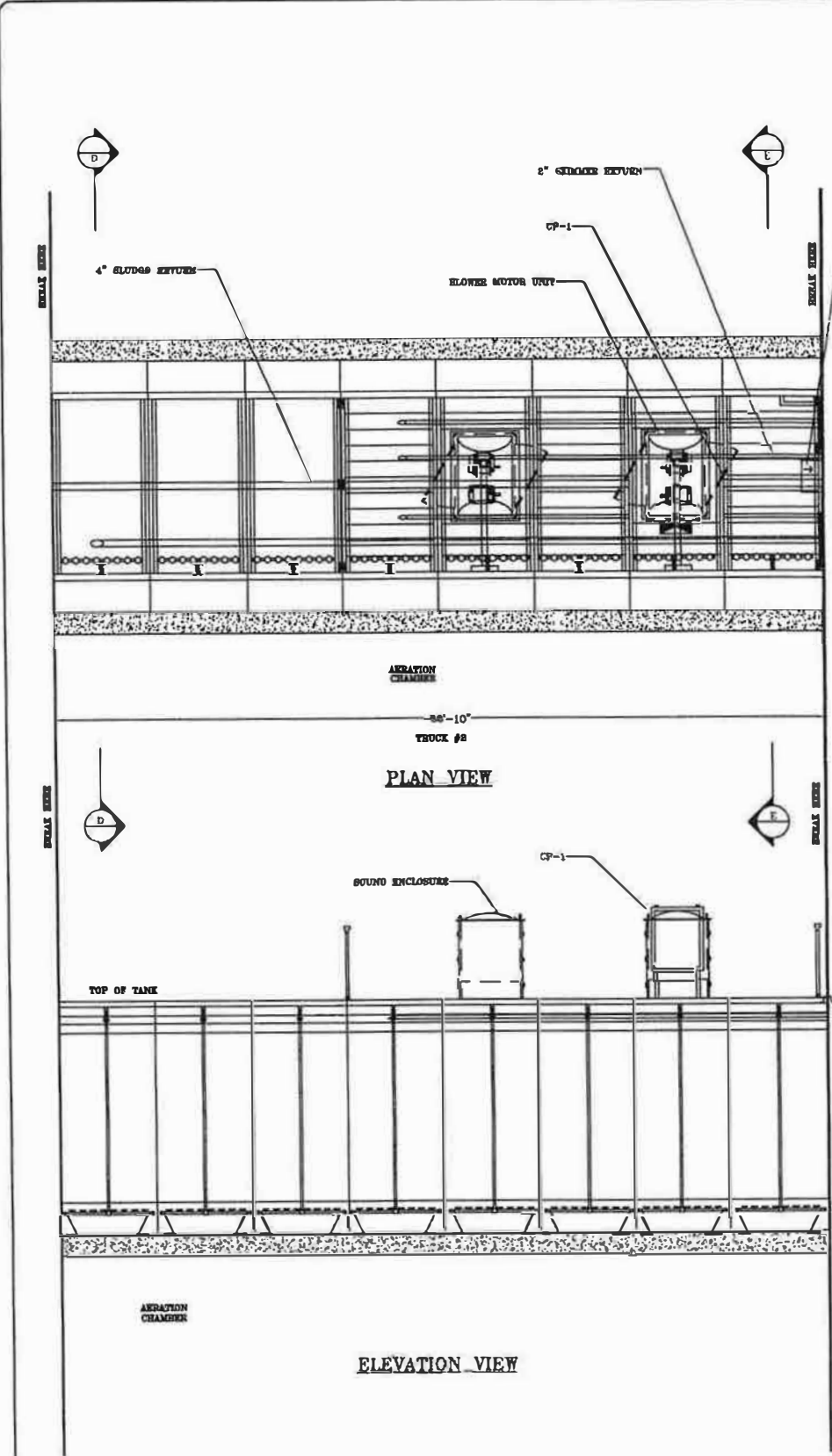

**Tipton Environmental International Inc.**  
 4448 STATE ROUTE 132  
 BATAVIA, OH 45103  
 USA  
 WWW.TIPTONENV.COM  
 PHONE: (618) 735-2777  
 FAX: (618) 735-1485

REVISIONS:	DESCRIPTION:
DATE:	BY:

**PROJECT NAME:**  
 RE-UNION SUBDIVISION  
 Saline County, Arkansas  
 Total Design Flow = 50,000 GPD

**DRAWING:**  
 SECTION VIEW

**PROJECT NO.:**  
 2005-054

**SCALE:**  
 NTS

**DATE:**  
 REVISED  
 6-16-05

**DRAWN BY:**  
 BS

**CHECKED BY:**

**APPROVED BY:**  
 FDT

**DWG NO.:**  
 05-054-04A

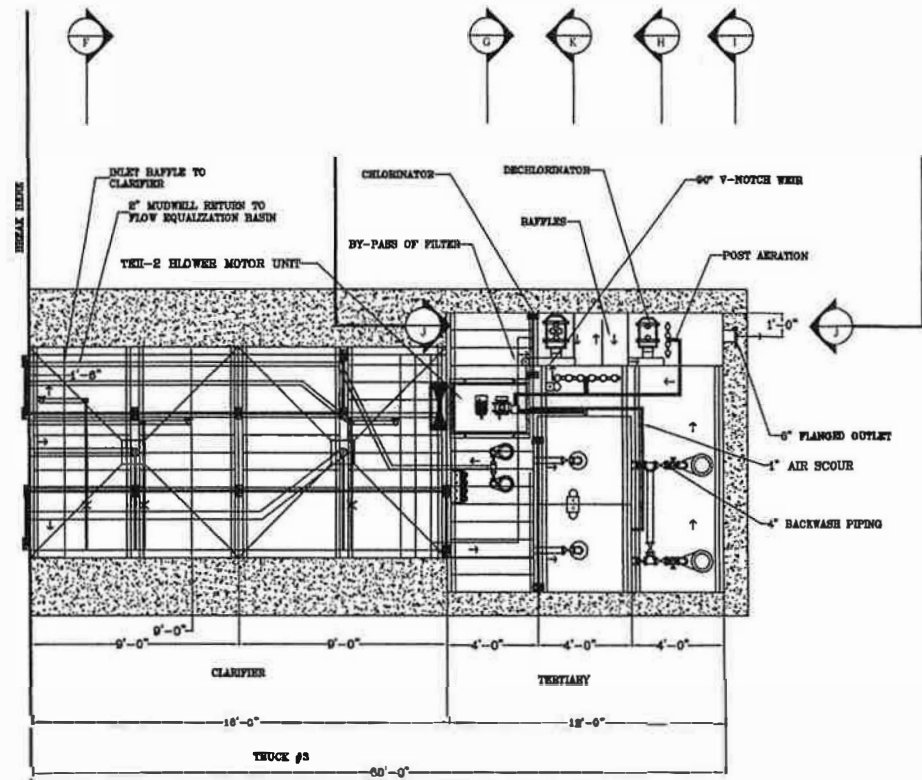

PLAN VIEW

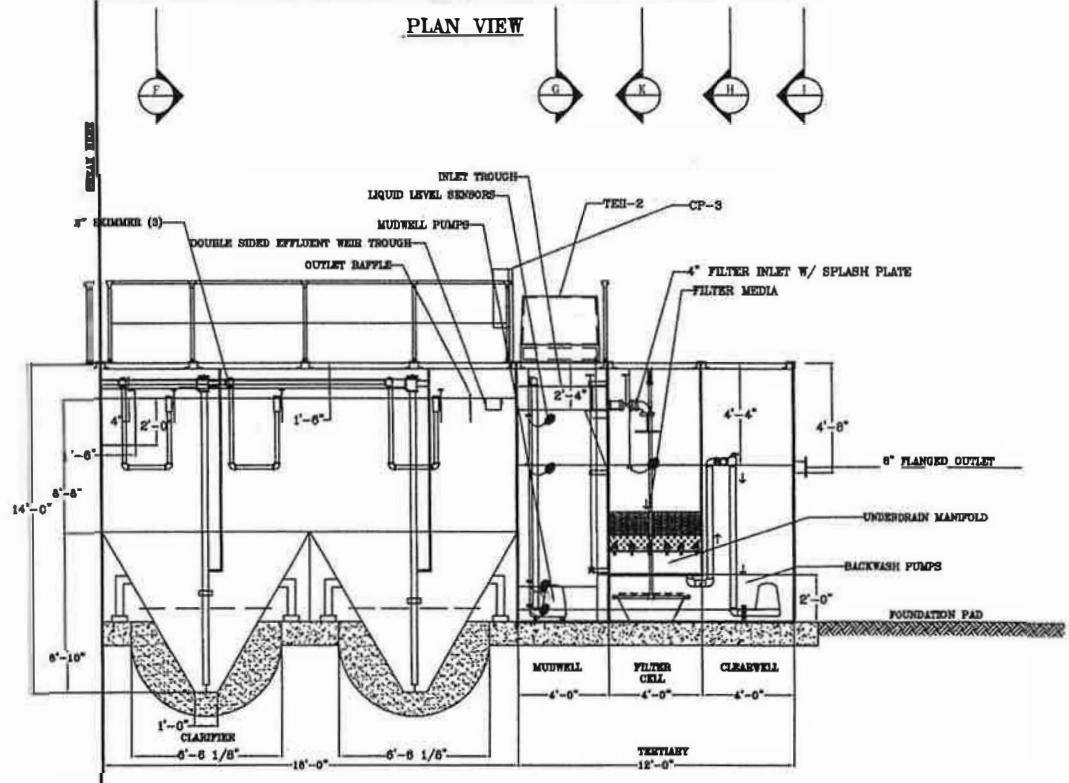

ELEVATION VIEW

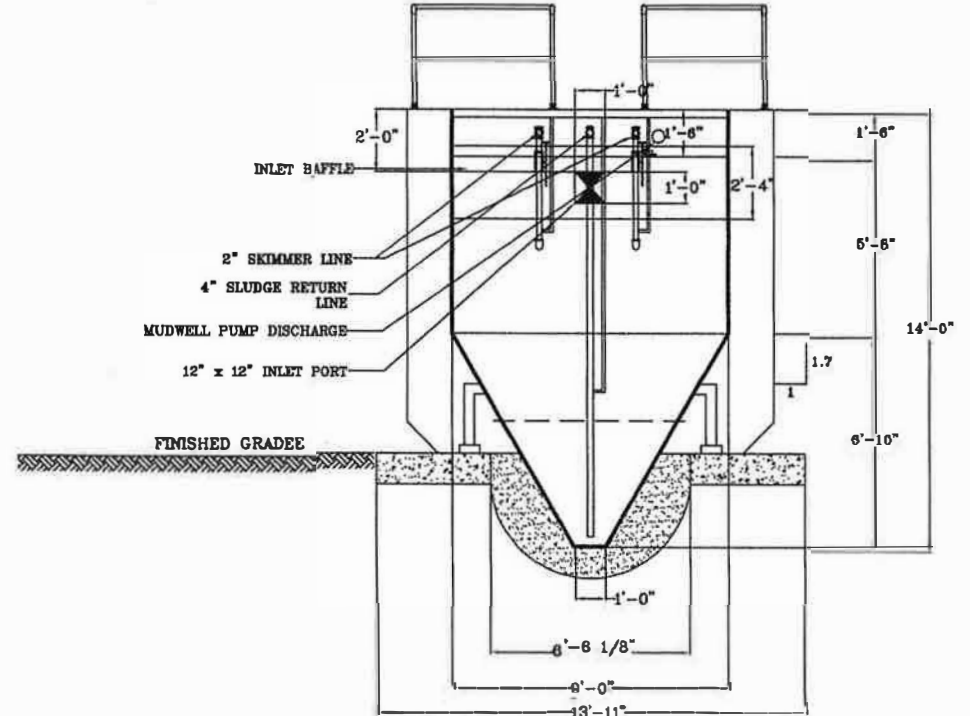

SECTION J-J  
CLARIFIER  
INLET END

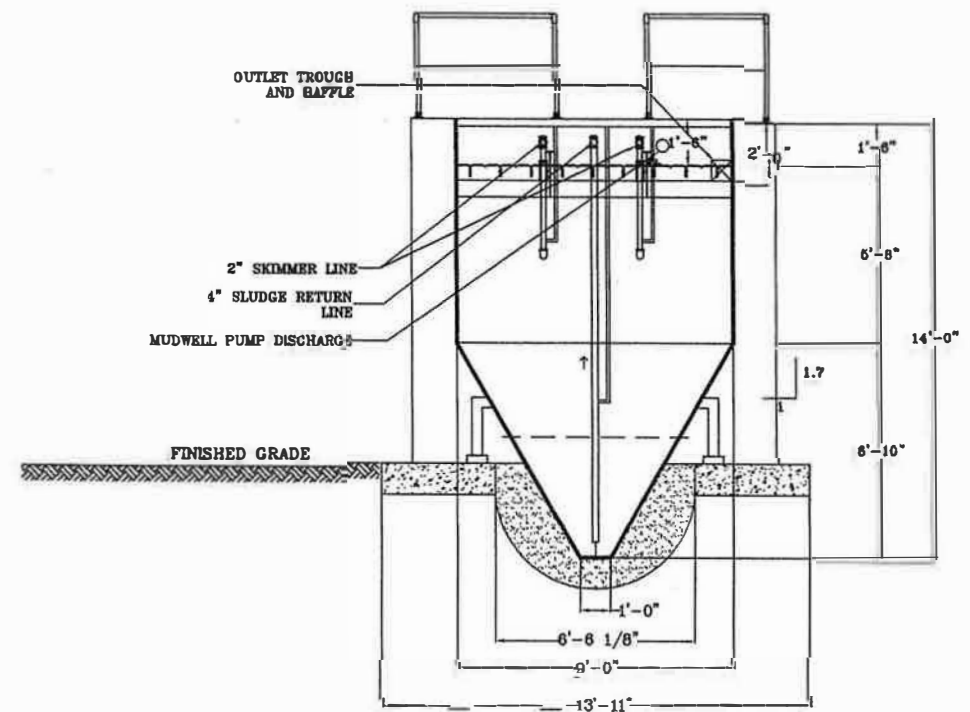

SECTION F-F  
CLARIFIER  
OUTLET END

Tipton Environmental  
**TIPTON ENVIRONMENTAL INTERNATIONAL INC.**  
 4448 STATE ROUTE 132  
 BATAVIA, OH 45103  
 USA  
 WWW.TIPTONENV.COM  
 PHONE: (613) 735-2777  
 FAX: (613) 735-1465

REVISIONS:	DESCRIPTION:
DATE:	BY:

PROJECT NAME:  
**RE-UNION SUBDIVISION**  
 Saline County, Arkansas  
 Total Design Flow= 50,000 GPD

DRAWING:  
**SECTION VIEW**

PROJECT NO.:  
 2005-054

SCALE:  
 NTS

DATE:  
 REVISED  
 6-18-05

DRAWN BY:  
 BS

CHECKED BY:

APPROVED BY:  
 FDT

DWG NO.:  
 05-054-05

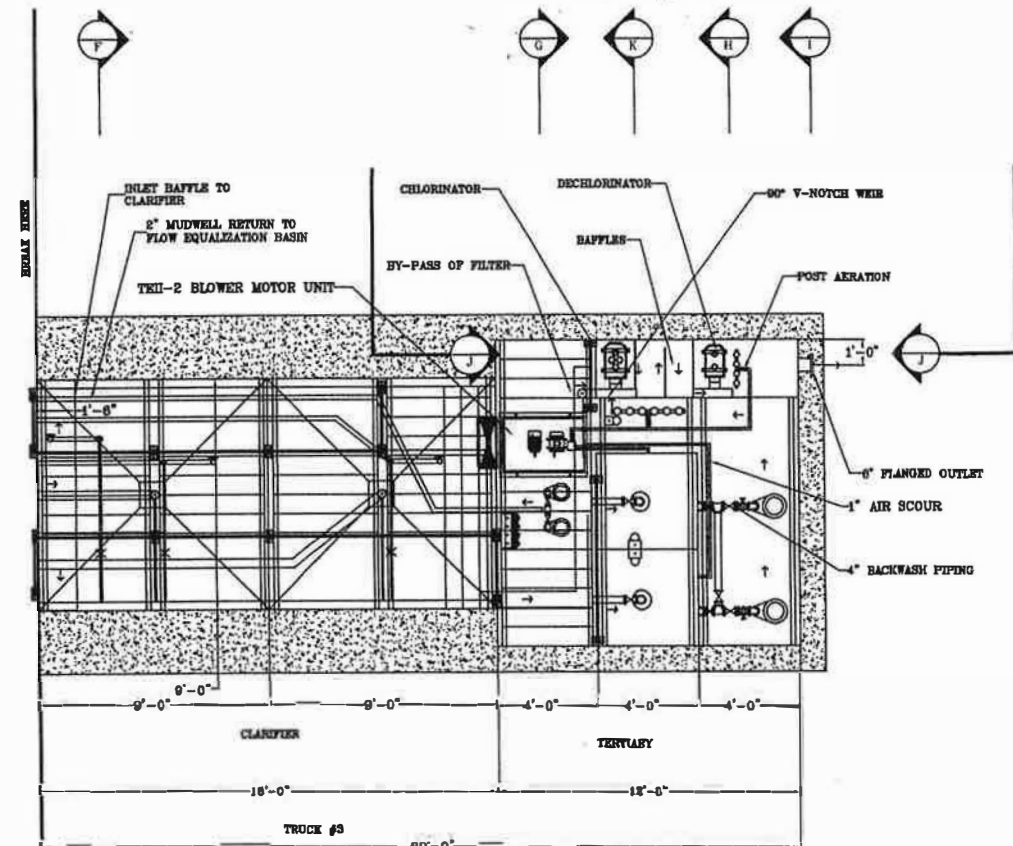

PLAN VIEW

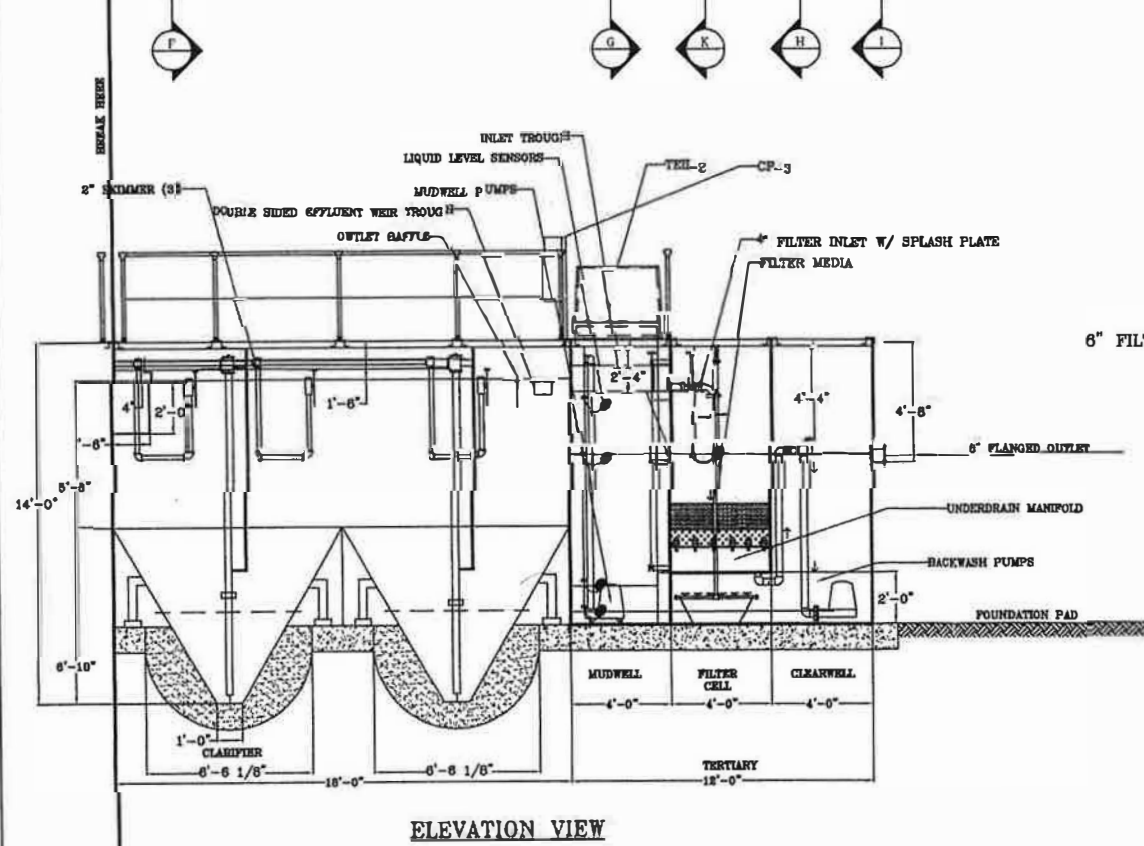

ELEVATION VIEW

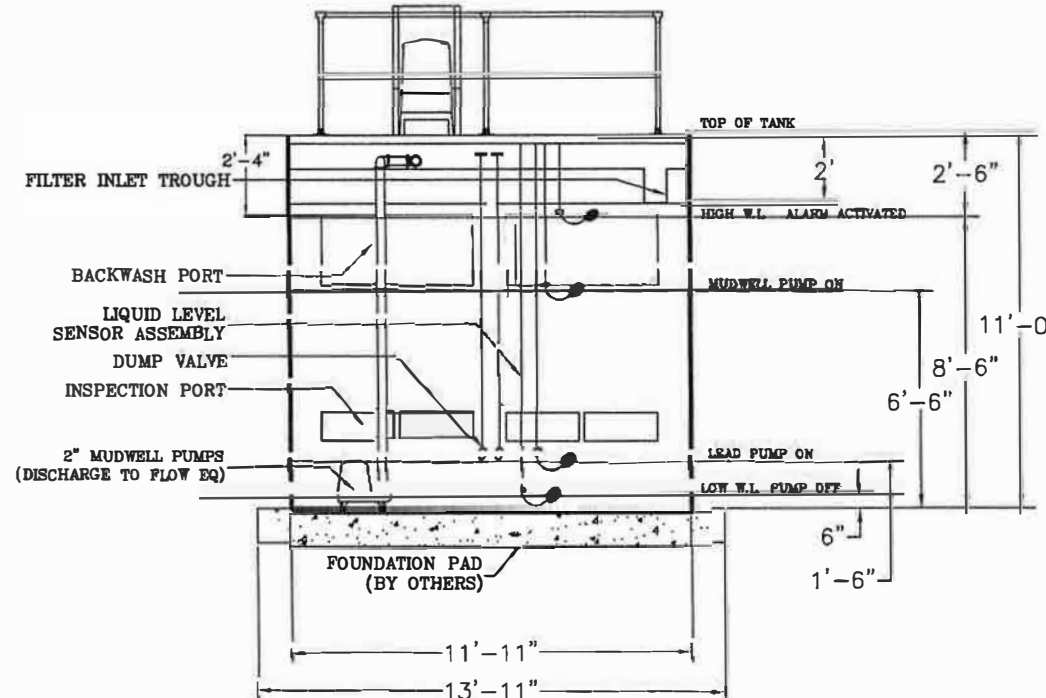

SECTION G-G  
MUDWELL

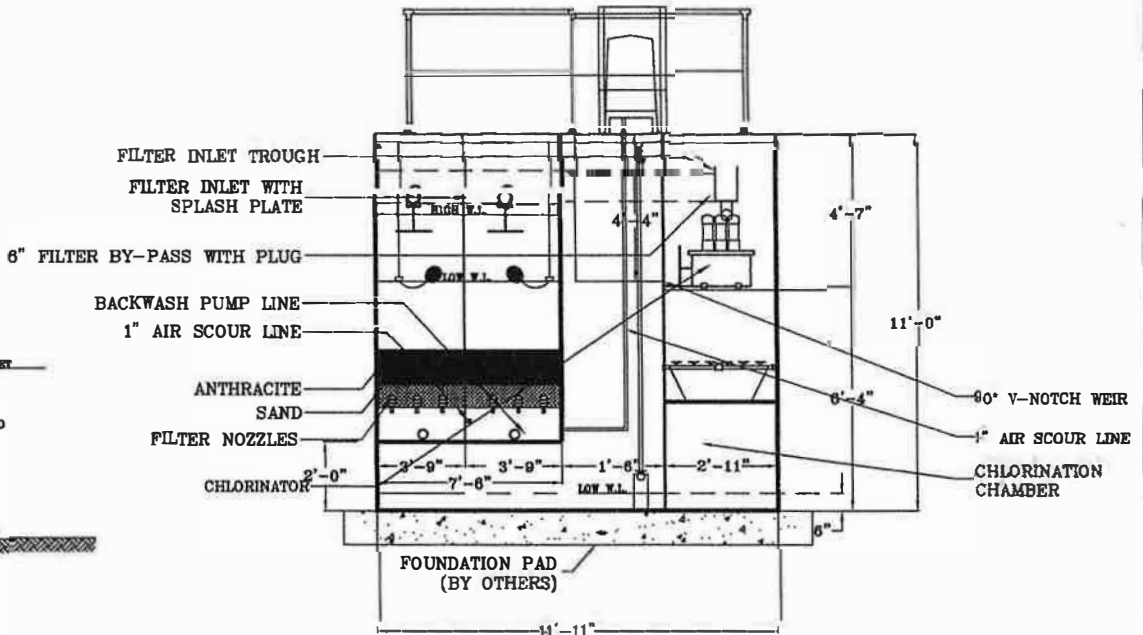

SECTION K-K  
FILTER/  
CHLORINATOR

**TIPTON ENVIRONMENTAL INTERNATIONAL INC.**  
 4446 STATE ROUTE 132  
 BATAVIA, OH 45103  
 USA  
 WWW.TIPTONENV.COM  
 PHONE: (513) 735-2777  
 FAX: (513) 735-1485

REVISIONS:	DESCRIPTION:
DATE:	BY:

PROJECT NAME:  
**RE-UNION SUBDIVISION**  
 Saline County, Arkansas  
 Total Design Flow= 50,000 GPD

DRAWING:  
 SECTION  
 VIEW

PROJECT NO.:  
 2005-054

SCALE:  
 NTS

DATE:  
 REVISED  
 6-18-05

DRAWN BY:  
 BS

CHECKED BY:

APPROVED BY:  
 FDT

DWG NO.:  
 05-054-06



**TIPTON ENVIRONMENTAL INTERNATIONAL, INC.**  
 4446 STATE ROUTE 132  
 BATAVIA, OH 45103  
 USA  
 WWW.TIPTONENV.COM  
 PHONE: (615) 735-2777  
 FAX: (615) 735-1485

REVISIONS:	DESCRIPTION:
DATE:	BY:

**PROJECT NAME:**  
 RE-UNION SUBDIVISION  
 Saline County, Arkansas  
 Total Design Flow= 50,000 GPD

**DRAWING:**  
 SECTION VIEW

**PROJECT NO.:**  
 2005-054

**SCALE:**  
 NTS

**DATE:**  
 REVISED  
 6-16-05

**DRAWN BY:**  
 BS

**CHECKED BY:**

**APPROVED BY:**  
 FDT

**DWG NO.:**  
 05-054-06A

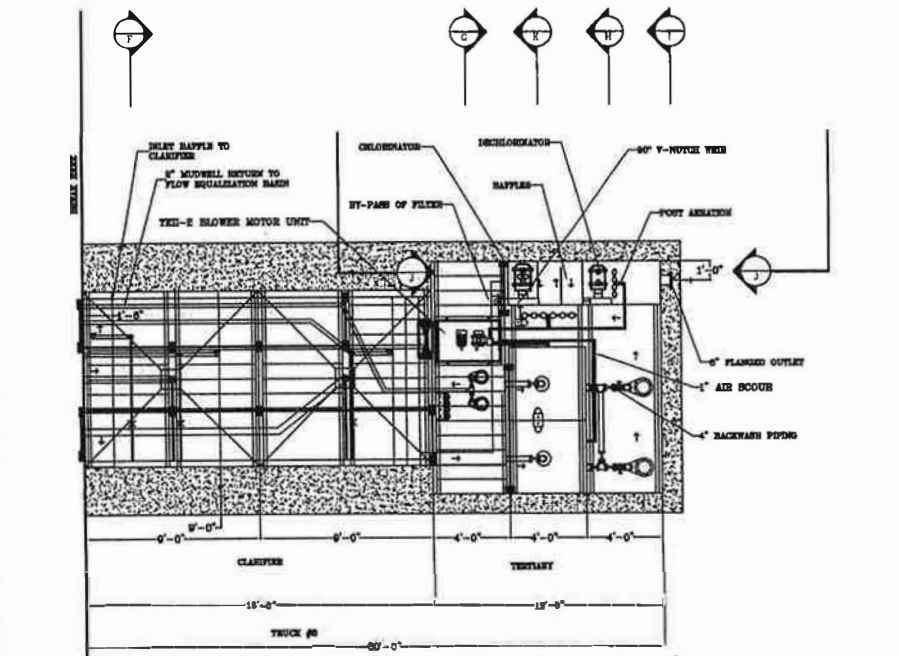

**PLAN VIEW**

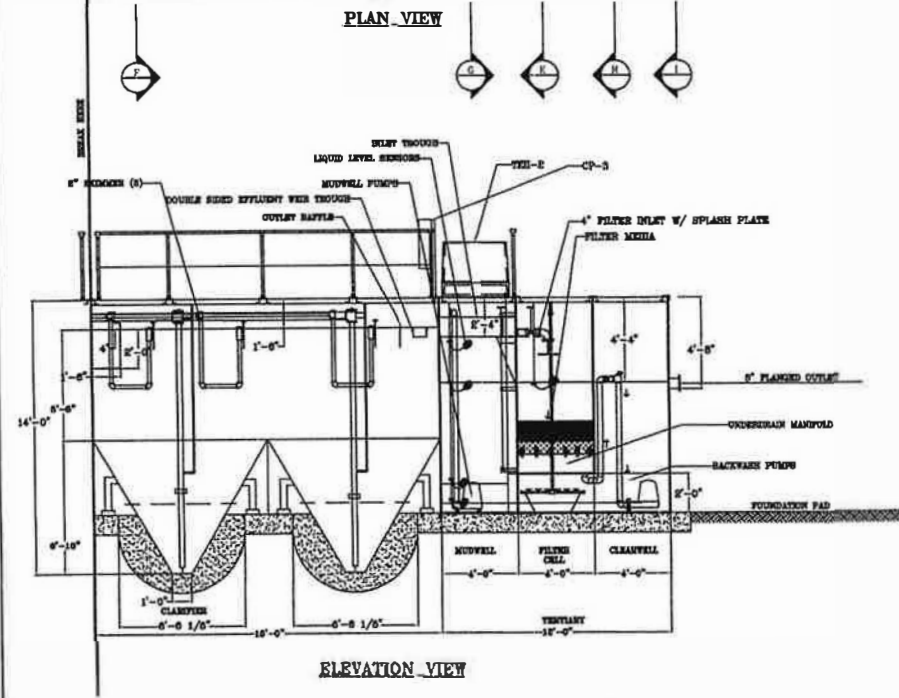

**ELEVATION VIEW**

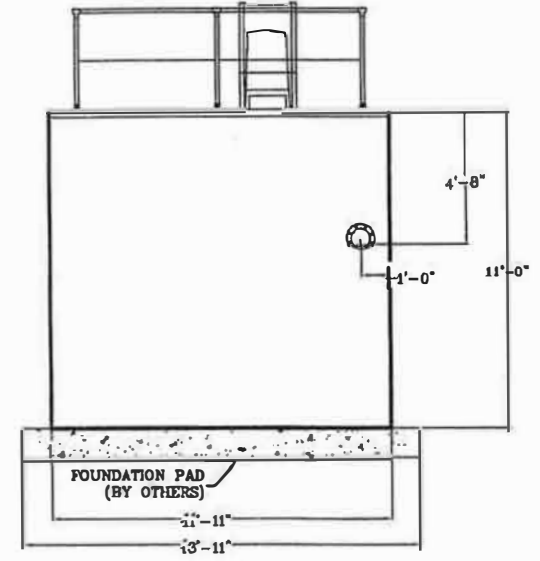

**ELEVATION -I-I  
 CL2 TANK**

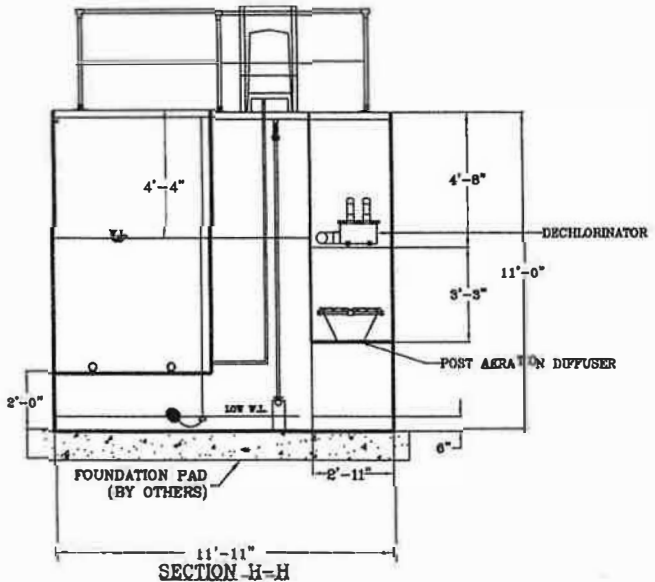

**SECTION H-H  
 FILTER/  
 DE-CHLORINATOR**

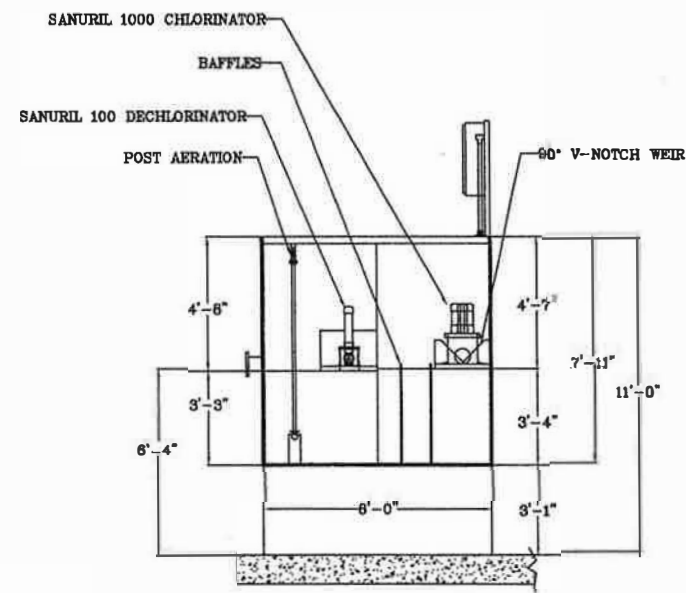

**SECTION -J-J  
 CL2 TANK**





Tipton Environmental  
**TIPTON ENVIRONMENTAL INTERNATIONAL INC.**  
 4440 STATE ROUTE 132  
 BATAVIA, OH 45103  
 USA  
 WWW.TIPTONENV.COM  
 PHONE: (613) 735-2777  
 FAX: (613) 735-1465

REVISIONS:	DESCRIPTION:
DATE:	BY:

**PROJECT NAME:**  
 REUNION SUBDIVISION  
 Saline County, Arkansas  
 Total Design Flow= 50,000 GPD

**DRAWING:**  
 PROCESS  
 FLOW  
 DIAGRAM

**PROJECT NO.:**  
 2005-054

**SCALE:**  
 NTS

**DATE:**  
 REVISED  
 6-16-05

**DRAWN BY:**  
 BS

**CHECKED BY:**

**APPROVED BY:**  
 FDT

**DWG NO.:**  
 05-054-07

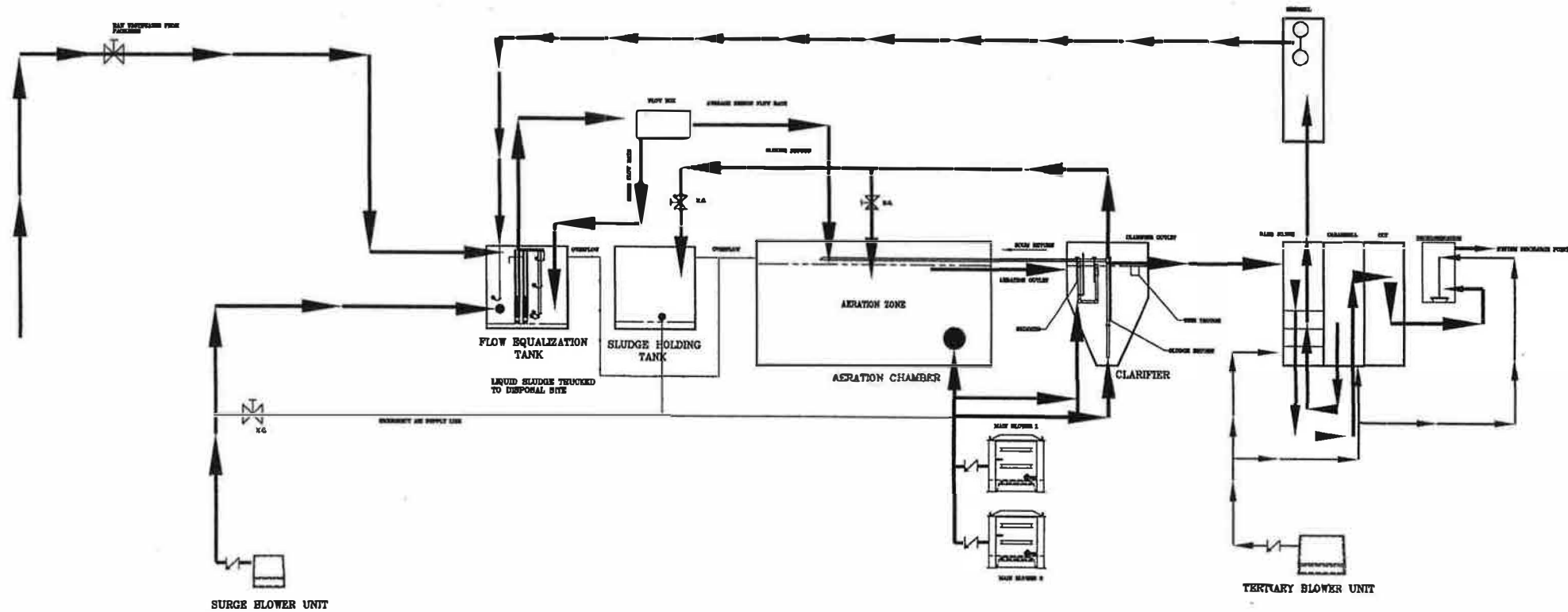

PROCESS FLOW DIAGRAM

LEGEND

- ▶ MAIN FLOW THROUGH WASTE WATER TREATMENT SYSTEM
- ▶ SURGE FLOW BY-PASS AND RETURN
- ▶ SURGE BLOWER AIR SUPPLY
- ▶ SLUDGE RETURN PUMP SYSTEM
- ▶ MAIN AIR BLOWER UNITS



Tipton Environmental  
**TIPTON ENVIRONMENTAL INTERNATIONAL INC.**  
 4446 STATE ROUTE 132  
 HATAVIA, OH 45163  
 USA  
 WWW.TIPTONENV.COM  
 PHONE: (615) 755-2777  
 FAX: (615) 755-1485

REVISIONS:	DESCRIPTION:
DATE:	BY:

PROJECT NAME:  
**RE-UNION SUBDIVISION**  
 Saline County, Arkansas  
 Total Design Flow = 50,000 GPD

DRAWING:  
**FOUNDATION LAYOUT**

PROJECT NO.:  
 2005-054

SCALE:  
 NTS

DATE:  
 REVISED  
 6-16-05

DRAWN BY:  
 BS

CHECKED BY:

APPROVED BY:  
 FDT

DWG NO.:  
 05-054-08

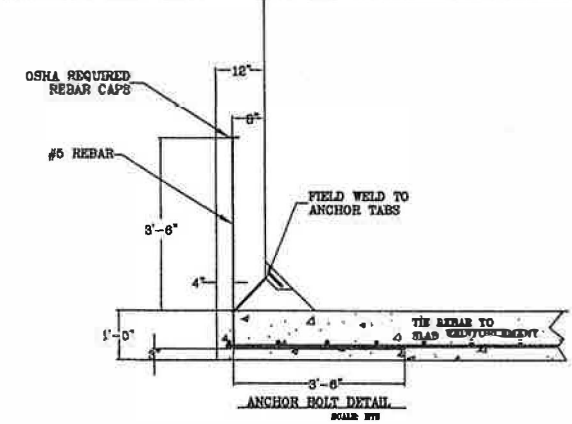
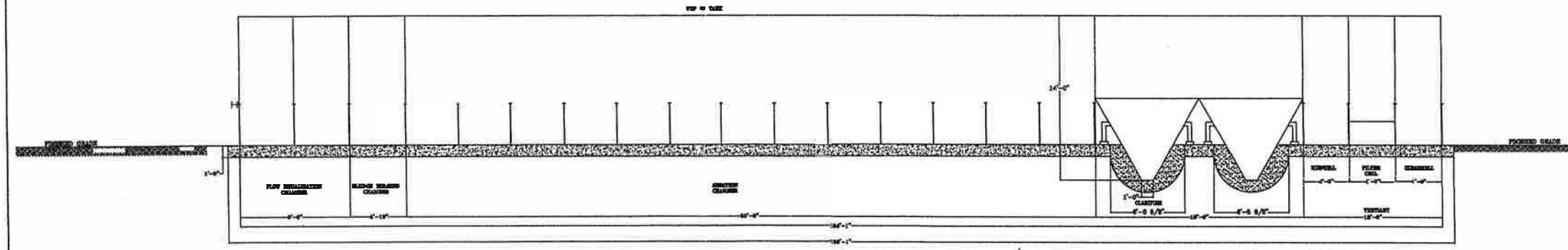
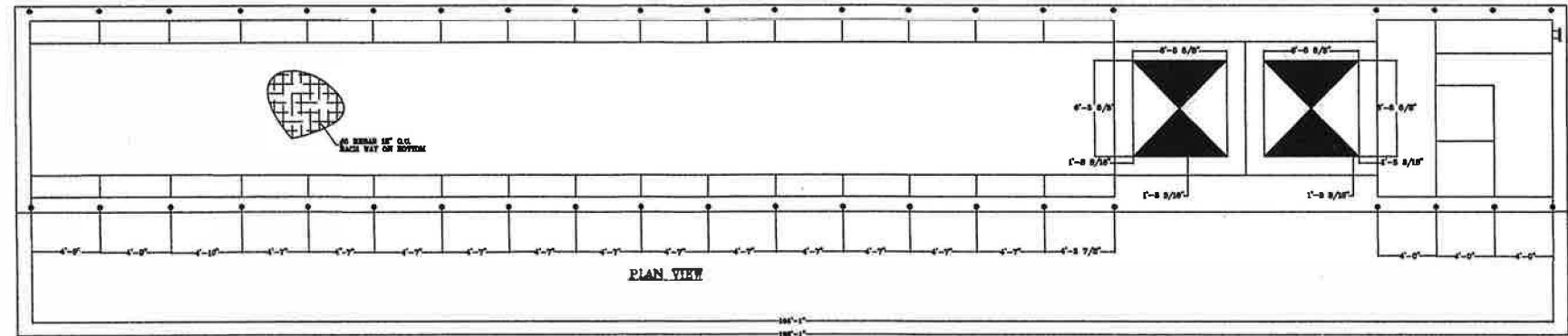

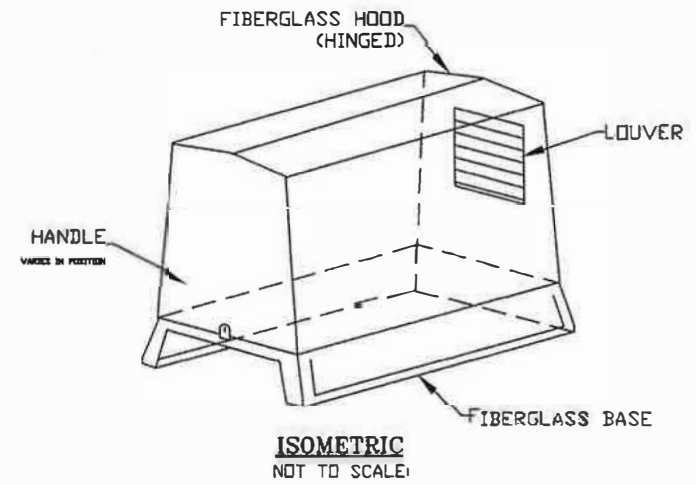
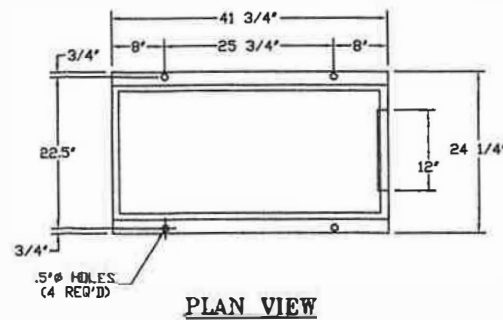

TEII-2

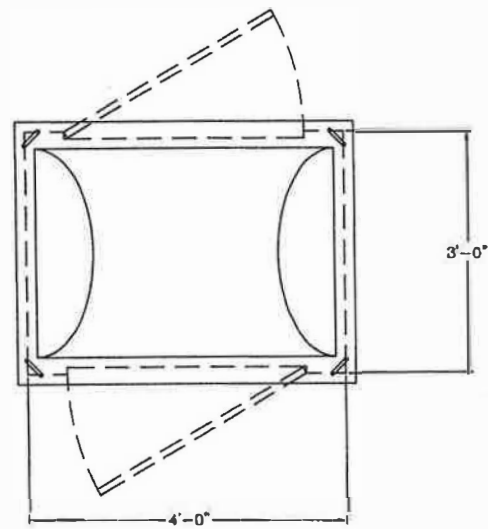
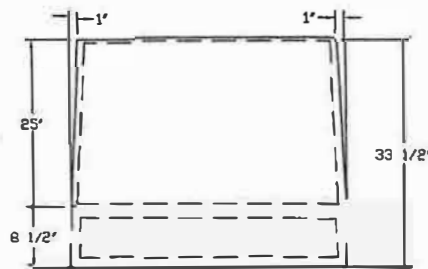

NOTE:  
1) BLOWER DISCHARGE HOLE & LOCATION DIM. VARIES BY SIZE

SOUND ENCLOSURE

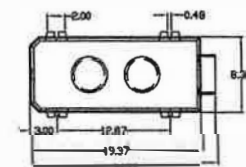
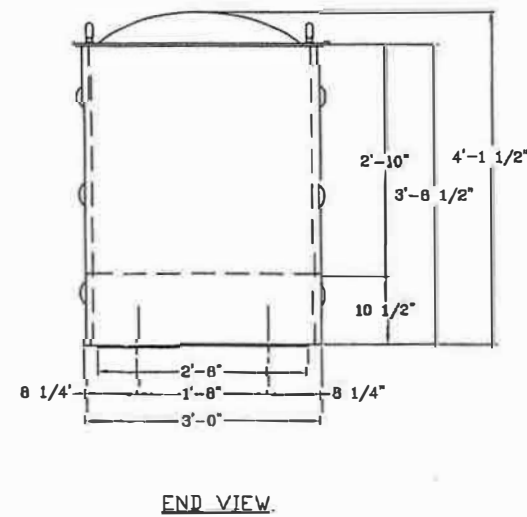
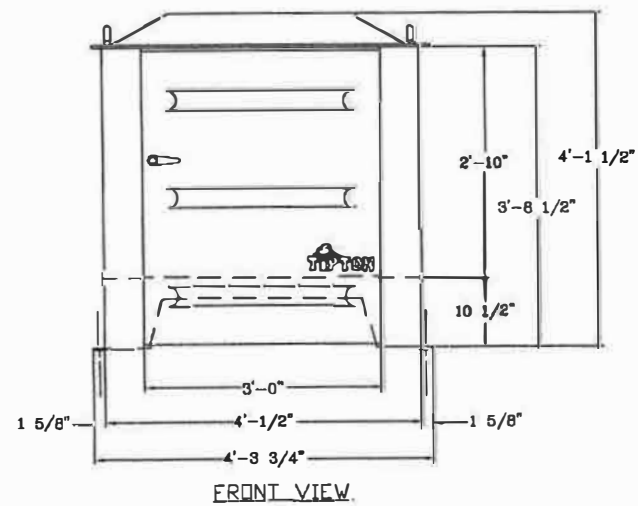

IQP VIEW

SANURIL-100 DECHLORINATOR  
DETAIL

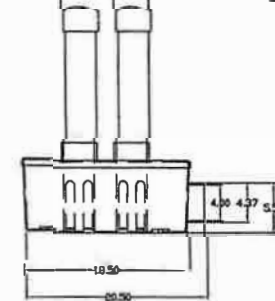

FRONT VIEW

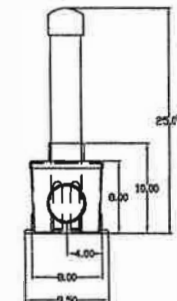

SIDE VIEW



Tipton Environmental  
TIPTON ENVIRONMENTAL INTERNATIONAL INC.  
4448 STATE ROUTE 132  
BATAVIA, OH 45103  
USA  
WWW.TIPTONENV.COM  
PHONE: (615) 735-2777  
FAX: (615) 735-1465

REVISIONS:	DESCRIPTION:
DATE:	BY:

PROJECT NAME:  
RE-UNION SUBDIVISION  
Saline County, Arkansas  
Total Design Flow = 50,000 GPD

DRAWING:  
DETAILS

PROJECT NO.:  
2005-054

SCALE:  
NTS

DATE:  
REVISED  
6-16-05

DRAWN BY:  
BS

CHECKED BY:

APPROVED BY:  
FDT

DWG NO.:  
05-054-09A



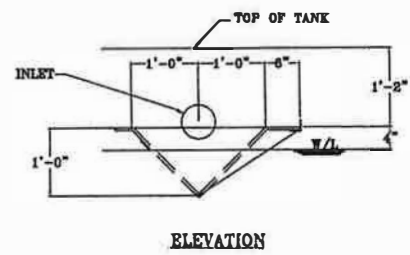

ELEVATION

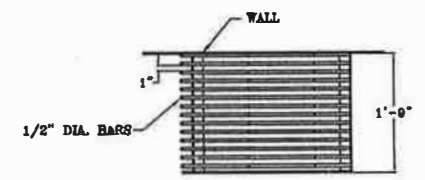

PLAN

**BARSCREEN DETAIL**

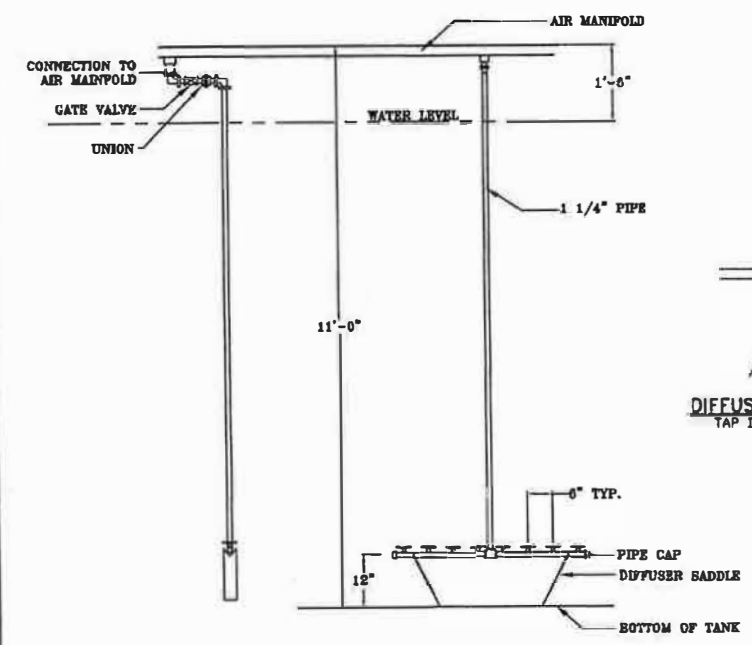

**DIFFUSER ASSEMBLY**  
NOTE: NUMBER OF DIFFUSERS VARIES WITH CHAMBER LENGTH

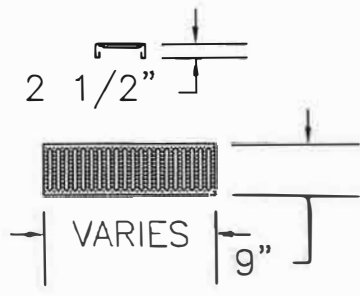

**GRATING DETAIL**  
NOTE: \* VARIES WITH CHAMBER LENGTH

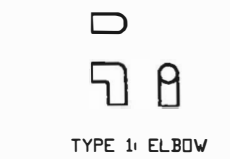

TYPE 1: ELBOW

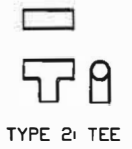

TYPE 2: TEE

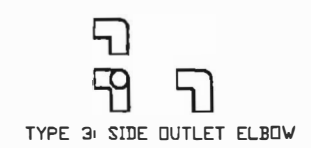

TYPE 3: SIDE OUTLET ELBOW

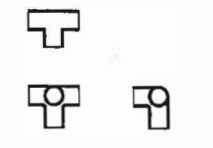

TYPE 4: SIDE OUTLET TEE



TYPE 5: SIDE OUTLET STAIR LANDING TEE

**HANDRAIL DETAIL**

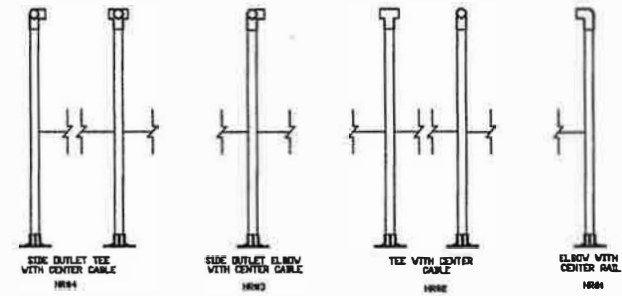

HANDRAILS WITH CENTER CABLE

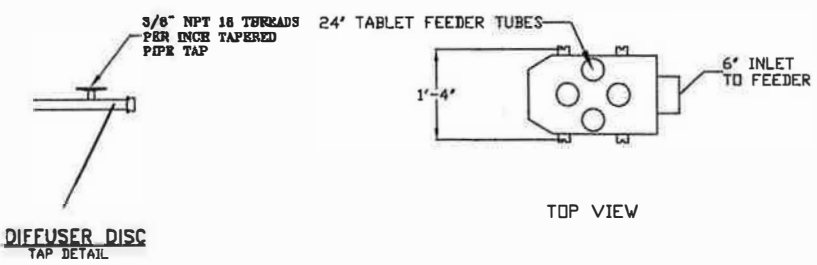

**DIFFUSER DISC TAP DETAIL**

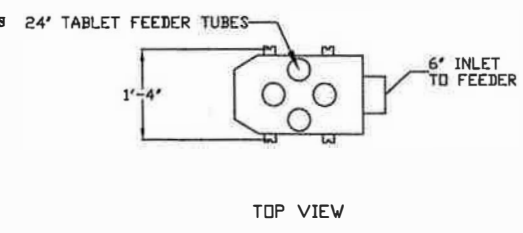

TOP VIEW

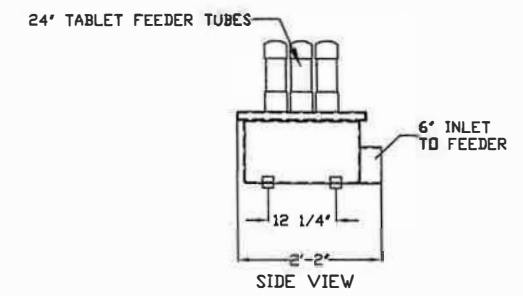

SIDE VIEW

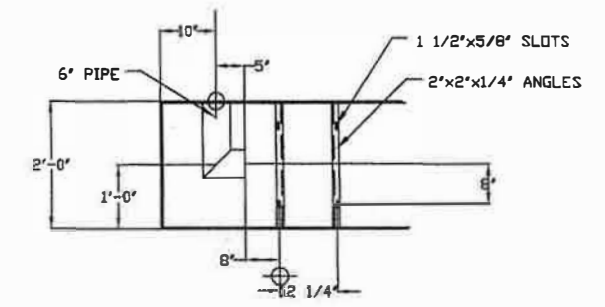

SANURIL 1000 MOUNTING

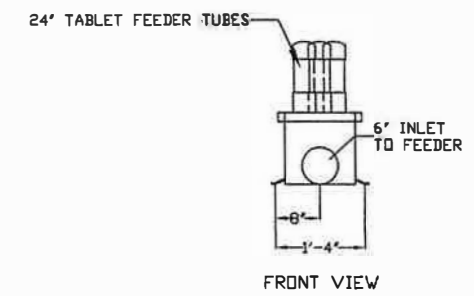

FRONT VIEW

**CHLORINATOR DETAIL**

Tipton Environmental  
TIPTON ENVIRONMENTAL INTERNATIONAL INC.  
444 STATE ROUTE 132  
BATAVIA, OH 45103 USA  
WWW.TIPTONENV.COM  
PHONE: (513) 735-2777  
FAX: (513) 735-1485

REVISIONS:	DESCRIPTION:
DATE:	
BY:	

PROJECT NAME:  
RE-UNION SUBDIVISION  
Saline County, Arkansas  
Total Design Flow= 50,000 GPD

DRAWING:  
DETAILS

PROJECT NO.:  
2005-054

SCALE:  
NTS

DATE:  
REVISED  
8-18-05

DRAWN BY:  
BS

CHECKED BY:

APPROVED BY:  
FDT

DWG NO.:  
05-054-09

REVISIONS:	DESCRIPTION:
DATE:	BY:

**PROJECT NAME:**  
 RE-UNION SUBDIVISION  
 Saline County, Arkansas  
 Total Design Flow = 50,000 GPD

**DRAWING:**  
 FLOW PROPORTIONING BOX DETAILS

**PROJECT NO.:**  
 2005-054

**SCALE:**  
 NTS

**DATE:**  
 REVISED  
 8-18-05

**DRAWN BY:**  
 BS

**CHECKED BY:**  
 FDT

**APPROVED BY:**  
 FDT

**DWG NO.:**  
 05-054-10

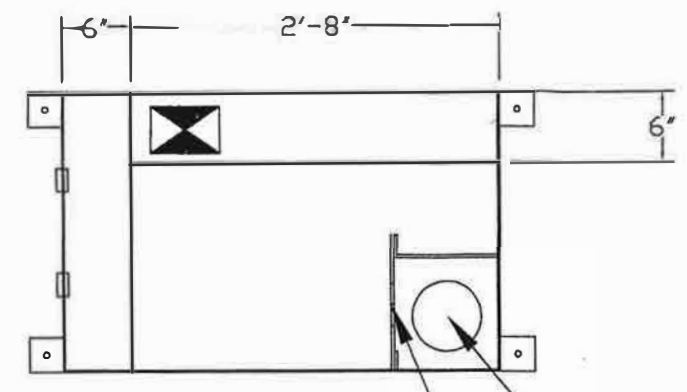

**PLAN**

6" PIPE  
 30° V-NOTCH WEIR

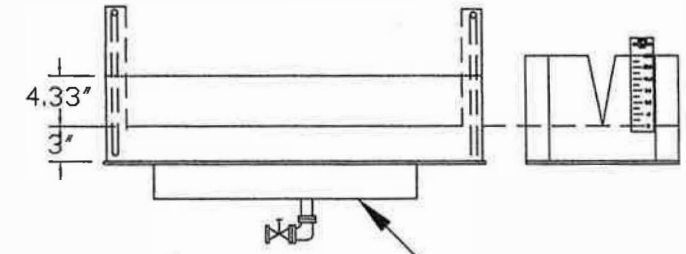

GRIT COLLECTION ZONE

**FLOW PROPORTIONING CHAMBER  
W/ GRIT COLLECTION ZONE**

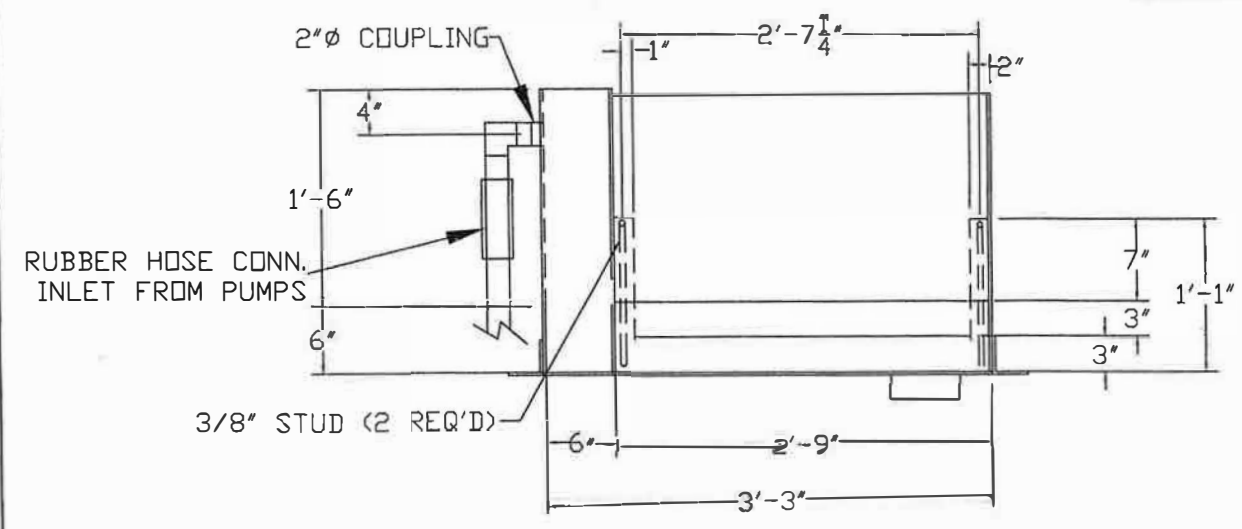

**SIDE VIEW**

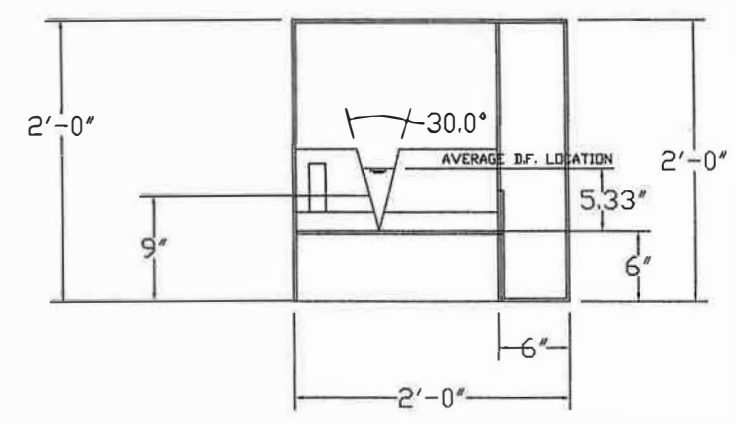

**END VIEW**

# SITE LOCATION DRAWINGS

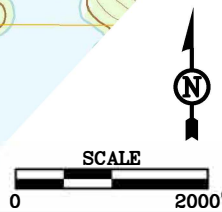
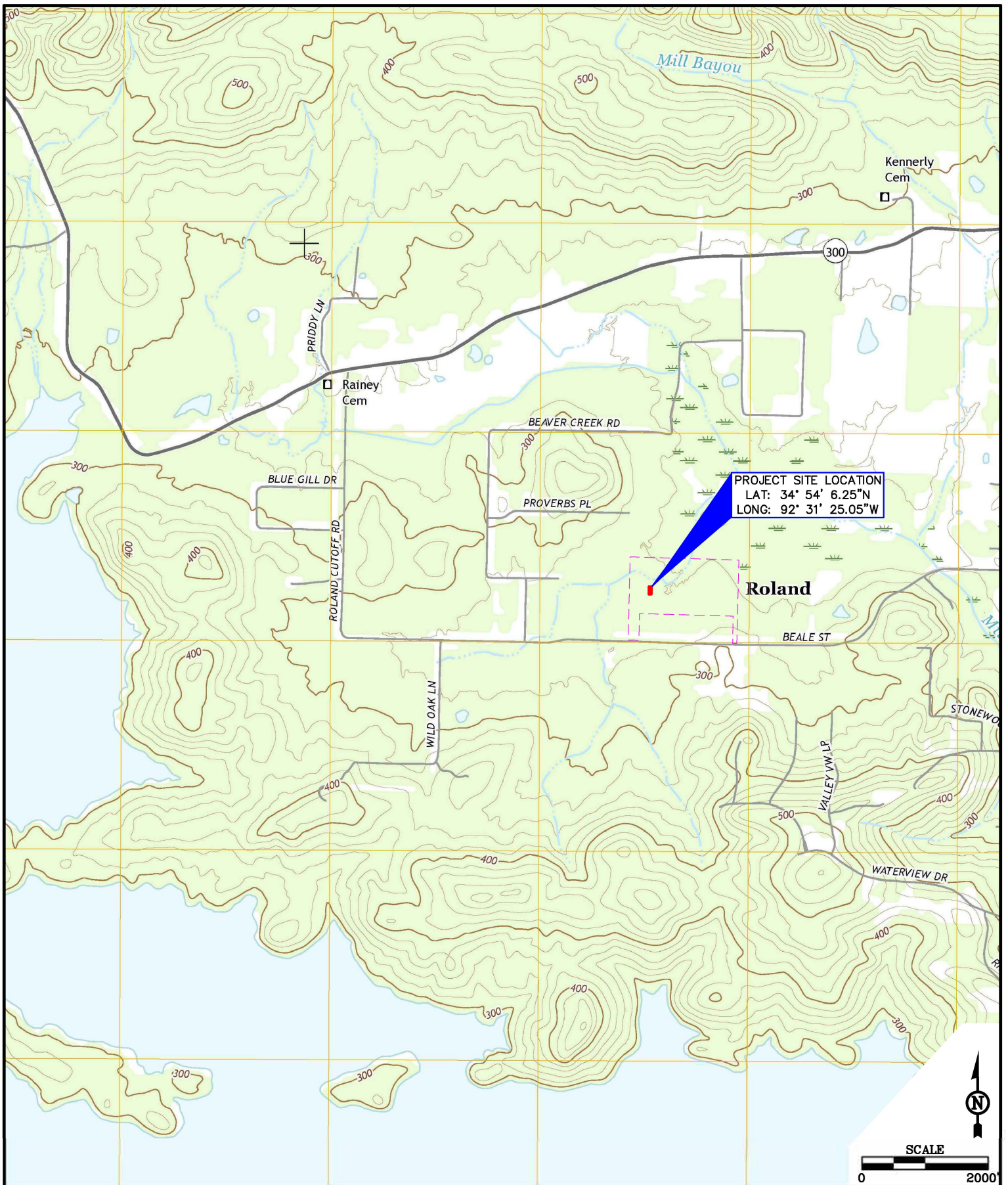

**CIVIL ENGINEERING AND ENVIRONMENTAL SERVICES**  
 3512 South Shackelford Road  
 Little Rock, Arkansas 72205  
 (501) 221-7122 fx: (501) 221-7775

**VICINITY MAP**

**WASTEWATER TREATMENT DESIGN & PERMITTING**  
 SADDLE RANCH SUBDIVISION  
 ROLAND CUTOFF ROAD  
 ROLAND, ARKANSAS

**JOB NUMBER:**  
 FERG-11791

**FIGURE NO.:**  
 1

**SUBMITTED:** D. FORD | **DRAWN:** C. GLOVER | **CHECKED:** D. FORD | **DATE:** AUG. 6, 2020

FILE: L:\FERGUSON, RICK\FERG-11791 - SADDLE RANCH WASTEWATER TREATMENT DESIGN - ROLAND SUBDIVISION\DRAWINGS\FERG-11791-NPDES.DWG



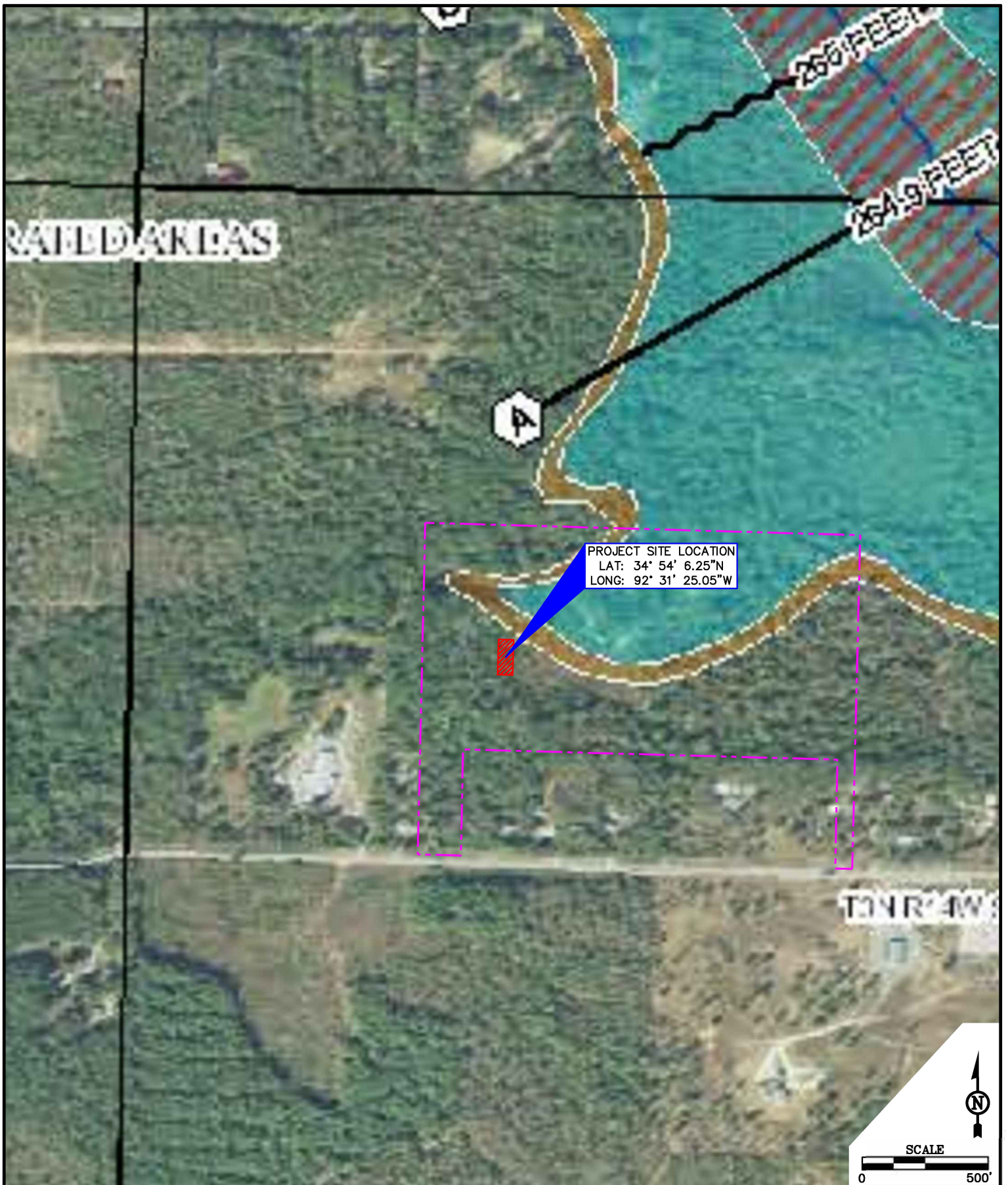

**CIVIL ENGINEERING AND ENVIRONMENTAL SERVICES**  
 3512 South Shackelford Road  
 Little Rock, Arkansas 72205  
 (501) 221-7122 fx: (501) 221-7775

SUBMITTED: D. FORD DRAWN: C. GLOVER CHECKED: D. FORD DATE: AUG. 10, 2020

FEMA FLOOD MAP  
 WASTEWATER TREATMENT DESIGN & PERMITTING  
 SADDLE RANCH SUBDIVISION  
 ROLAND CUTOFF ROAD  
 ROLAND, ARKANSAS

JOB NUMBER:  
 FERG-11791  
 FIGURE NO.:  
 2



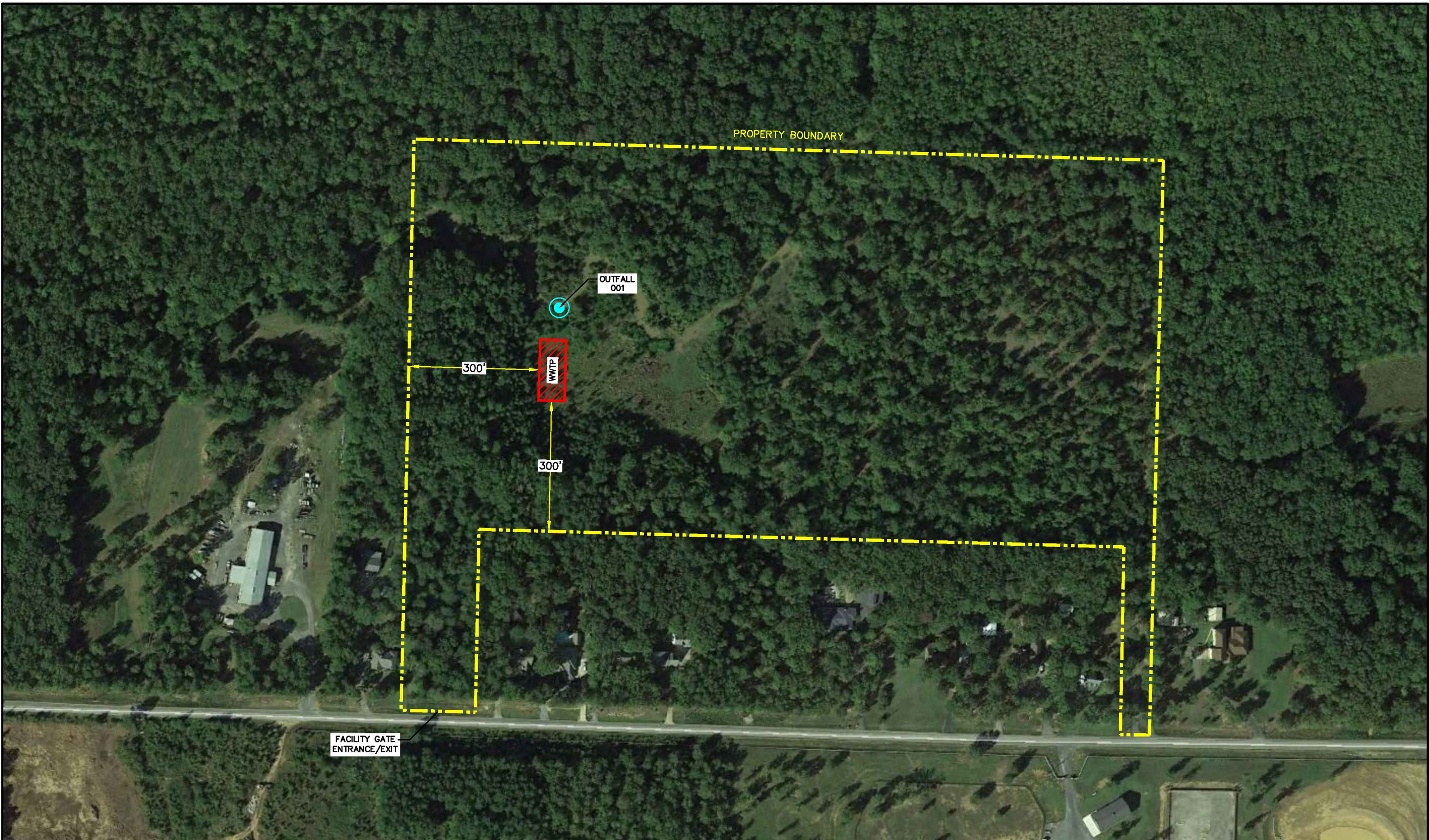

**CIVIL ENGINEERING AND ENVIRONMENTAL SERVICES**  
 3512 South Shackleford Road  
 Little Rock, Arkansas 72205  
 (501) 221-7122 fax (501) 221-7775

SUBMITTED:	D. FORD
DRAWN:	C. GLOVER
CHECKED:	D. FORD
DATE:	JUNE 17, 2020



**WASTEWATER TREATMENT DESIGN & PERMITTING**  
 SADDLE RANCH SUBDIVION  
 ROLAND CUTOFF ROAD  
 ROLAND, ARKANSAS

**NPDES PERMIT**  
**AERIAL SITE LAYOUT**

<b>JOB NUMBER</b>	FERG-11791
<b>DRAWING NO.</b>	1

FILE: L:\FERGUSON, RICK\FERG-11791 - SADDLE RANCH WASTEWATER TREATMENT DESIGN - ROLAND SUBDIVISION\DRAWINGS\FERG-11791-NPDES.DWG



# SECRETARY STATE OF ARKANSAS DOCUMENTS

# STATE OF ARKANSAS



**John Thurston**

ARKANSAS SECRETARY OF STATE

To All to Whom These Presents Shall Come, Greetings:

I, John Thurston, Arkansas Secretary of State of Arkansas, do hereby certify that the following and hereto attached instrument of writing is a true and perfect copy of

## **Articles of Organization**

of

## **SOUTHWEST EQUITY INVESTMENTS, LLC**

filed in this office  
December 30, 2019

**In Testimony Whereof**, I have hereunto set my hand and affixed my official Seal. Done at my office in the City of Little Rock, this 30th day of December 2019.

  
John Thurston  
Secretary of State

Online Certificate Authorization Code: 2824875e0a41cd7f46d  
To verify the Authorization Code, visit [sos.arkansas.gov](http://sos.arkansas.gov)







# Articles of Organization for Domestic LLC

## Filing Information

**Filing Act:** 1003 of 1993  
**Entity Name:** SOUTHWEST EQUITY INVESTMENTS, LLC  
**File Date:** 2019-12-30 10:35:39  
**Effective Date:** 2019-12-30  
**Filing Signature:** PRICE C GARDNER  
**Manager Statement:** MANAGMENT IS VESTED IN ONE OR MORE MANAGERS

## Registered Agent:

**First Name:** PRICE  
**Middle Name:** C  
**Last Name:** GARDNER  
**Address 1:** 400 WEST CAPITOL SUITE 2000  
**City:** LITTLE ROCK  
**State:** AR  
**Zip:** 72201  
**Country:** USA

## Officers

**First Name:** PRICE  
**Middle Name:** C  
**Last Name:** GARDNER  
**Title:** Incorporator/Organizer  
**Address 1:** 400 WEST CAPITOL AVE #2000  
**City:** LITTLE ROCK  
**State:** AR  
**Zip:** 72201  
**Country:** USA

## Principal

**First Name:** PRICE  
**Middle Name:** C  
**Last Name:** GARDNER  
**Address 1:** 400 WEST CAPITOL SUITE 2000  
**City:** LITTLE ROCK  
**State:** AR  
**Zip:** 72201  
**Country:** USA

# DISCLOSURE STATEMENT

# INSTRUCTIONS FOR DISCLOSURE STATEMENT

Arkansas Code Annotated Section 8-1-106 requires that all applicants for the issuance, or transfer of any permit, license, certification or operational authority issued by the Arkansas Department of Environmental Quality (ADEQ) file a disclosure statement with their applications. The filing of a disclosure statement is mandatory. No application can be considered complete without one.

Disclosure statement means a written statement by the applicant that contains:

- The full name and business address of the applicant and all affiliated persons;
- The full name and business address of any legal entity in which the applicant holds a debt or equity interest of at least five percent (5%) or that is a parent company or subsidiary of the applicant, and a description of the ongoing organizational relationships as they may impact operations within the state;
- A description of the experience and credentials of the applicant, including any past or present permits, licenses, certifications, or operational authorizations relating to environmental regulation;
- A listing and explanation of any civil or criminal legal actions by government agencies involving environmental protection laws or regulations against the applicant and affiliated persons in the ten (10) years immediately preceding the filing of the application, including administrative enforcement actions resulting in the imposition of sanctions, permit or license revocations or denials issued by any state or federal authority, actions that have resulted in a finding or a settlement of a violation, and actions that are pending;
- A listing of any federal environmental agency and any other environmental agency outside this state that has or has had regulatory responsibility over the applicant; and
- Any other information the Director of the Arkansas Department of Environmental Quality may require that relates to the competency, reliability, or responsibility of the applicant and affiliated persons.

## Exemptions:

The following persons or entities are not required to file a disclosure statement:

- Governmental entities, consisting only of subdivisions or agencies of the federal government, agencies of the state government, counties, municipalities, or duly authorized regional solid waste authorities as defined by § 8-6-702. (This exemption shall not extend to improvement districts or any other subdivision of government which is not specifically instituted by an act of the General Assembly.)
- Applicants for a general permit to be issued by the department pursuant to its authority to implement the National Pollutant Discharge Elimination System for storm water discharge.
- If the applicant is a publicly held company required to file periodic reports under the Securities and Exchange Act of 1934 or a wholly owned subsidiary of a publicly held company, the applicant shall not be required to submit a disclosure statement, but shall submit the most recent annual and quarterly reports required by the Securities and Exchange Commission which provide information regarding legal proceedings in which the applicant has been involved. The applicant shall submit such other information as the director may require that relates to the competency, reliability, or responsibility of the applicant and affiliated persons.

## **Exemptions continued:**

The following permits, licenses, certifications, and operational authorizations are also exempt from submitting a disclosure statement:

- **Hazardous Waste Treatment, Storage, and Disposal Permit Modifications (Class 1, 2, and 3), as defined in Arkansas Pollution Control and Ecology Commission (APC&EC) Regulation 23;**
- **Phase 1 Consultants, as defined in APC&EC Regulation 32;**
- **Certifications for Operators of Commercial Hazardous Waste Facilities, as defined in APC&EC Regulation 23 § 264.16(f);**
- **Regulated Storage Tank Contractor or Individual License Renewals as defined in APC&EC Regulation 12;**
- **Certifications for Persons Operating and Maintaining Underground Storage Tank Systems which Contain Regulated Substances, as defined in APC&EC Regulation 12.701, et. seq.;**
- **Individual Homeowners seeking coverage under General Permit ARG5500000; Wastewater Operator Licenses, as defined in APC&EC Regulation 3;**
- **Water Permit Modifications for permits issued under the authority of the Arkansas Water and Air Pollution Control Act (Ark. Code Ann. §8-4-101, et. seq.);**
- **Solid Waste Permit Modifications for permits issued under APC&EC Regulation 22; Solid Waste Landfill Operator License Renewals, as defined in Regulation No. 27;**
- **Air Permit Modifications for permits issued under APC&EC Regulations 18, 19, and 26; and Asbestos Certification Renewals, as defined in Regulation 21.**

**Deliberate falsification or omission of relevant information from disclosure statements shall be grounds for civil or criminal enforcement action or administrative denial of a permit, license, certification, or operational authorization.**

# ARKANSAS DEPARTMENT OF ENVIRONMENTAL QUALITY DISCLOSURE STATEMENT

## Instructions for the Completion of this Document:

- A. Individuals, firms or other legal entities with no changes to an ADEQ Disclosure Statement, complete items 1 through 5 and 18.**
- B. Individuals who never submitted an ADEQ Disclosure Statement, complete items 1 through 4, 6, 7, and 16 through 18.**
- C. Firms or other legal entities who never submitted an ADEQ Disclosure Statement, complete 1 through 4, and 6 through 18.**

If Not Submitting by ePortal, Mail Original to:

**ADEQ  
DISCLOSURE STATEMENT  
[List Proper Division(s)]  
5301 Northshore Drive  
North Little Rock, AR 72118-5317**

1. APPLICANT: (Full Name)

Southwest Equity Investments, LLC

2. MAILING ADDRESS: (Number and Street, P.O.Box Or Rural Route)

P.O. Box 23070

3. CITY, STATE, AND ZIPCODE:

Little Rock, Arkansas, 72221

4a. Applicant Type:

Individual  Corporate or Other Entity

4b. Reason for Submission:

Permit  License  Certification  Operational Authority

New Application  Modification  Renewal Application (If no changes from previous disclosure statement, complete number 5 and 18.)

4c. Programs:

Air  Water  Hazardous Waste  Regulated Storage Tank  Mining  Solid Waste  Used Tire Program

5. Declaration of No Changes:

The violation history, experience and credentials, involvement in current or pending environmental lawsuits, civil and criminal, have not changed since the last Disclosure Statement that was filed with ADEQ on \_\_\_\_\_

6. Describe the experience and credentials of the Applicant, including the receipt of any past or present permits, licenses, certifications or operational authorization relating to environmental regulation. (Attach additional pages, if necessary.)

Southwest Equity Investments, LLC (Southwest) is owned by Rick Ferguson. Rick Ferguson owns and operates Waterview Estates wastewater treatment plant. Rick Ferguson has a licensed wastewater operator (Arlo Jason Cyz) that is experienced in the operation of residential treatment plants. Rick Ferguson has experience with ADEQ permits and understands the regulations.

7. List and explain all civil or criminal legal actions by government agencies involving environmental protection laws or regulations against the Applicant \* in the last ten (10) years including:

1. Administrative enforcement actions resulting in the imposition of sanctions;
2. Permit or license revocations or denials issued by any state or federal authority;
3. Actions that have resulted in a finding or a settlement of a violation; and
4. Pending actions.

(Attach additional pages, if necessary.)

None

**8. List all officers of the Applicant. (add additional pages, if necessary.)**

NAME: Rick Ferguson TITLE: President  
STREET: P.O. Box 23070  
CITY, STATE, ZIP: Little Rock, Arkansas, 72221

NAME: \_\_\_\_\_ TITLE: \_\_\_\_\_  
STREET: \_\_\_\_\_  
CITY, STATE, ZIP: \_\_\_\_\_

NAME: \_\_\_\_\_ TITLE: \_\_\_\_\_  
STREET: \_\_\_\_\_  
CITY, STATE, ZIP: \_\_\_\_\_

**9. List all directors of the Applicant. (Add additional pages, if necessary.)**

NAME: \_\_\_\_\_ TITLE: \_\_\_\_\_  
STREET: \_\_\_\_\_  
CITY, STATE, ZIP: \_\_\_\_\_

NAME: \_\_\_\_\_ TITLE: \_\_\_\_\_  
STREET: \_\_\_\_\_  
CITY, STATE, ZIP: \_\_\_\_\_

NAME: \_\_\_\_\_ TITLE: \_\_\_\_\_  
STREET: \_\_\_\_\_  
CITY, STATE, ZIP: \_\_\_\_\_

**10. List all partners of the Applicant. (Add additional pages, if necessary.)**

NAME: \_\_\_\_\_ TITLE: \_\_\_\_\_  
STREET: \_\_\_\_\_  
CITY, STATE, ZIP: \_\_\_\_\_

NAME: \_\_\_\_\_ TITLE: \_\_\_\_\_  
STREET: \_\_\_\_\_  
CITY, STATE, ZIP: \_\_\_\_\_

NAME: \_\_\_\_\_ TITLE: \_\_\_\_\_  
STREET: \_\_\_\_\_  
CITY, STATE, ZIP: \_\_\_\_\_

**11. List all persons employed by the Applicant in a supervisory capacity or with authority over operations of the facility subject to this application.**

NAME: \_\_\_\_\_ TITLE: \_\_\_\_\_  
STREET: \_\_\_\_\_  
CITY, STATE, ZIP: \_\_\_\_\_

NAME: \_\_\_\_\_ TITLE: \_\_\_\_\_  
STREET: \_\_\_\_\_  
CITY, STATE, ZIP: \_\_\_\_\_

NAME: \_\_\_\_\_ TITLE: \_\_\_\_\_  
STREET: \_\_\_\_\_  
CITY, STATE, ZIP: \_\_\_\_\_

**12. List all persons or legal entities, who own or control more than five percent (5%) of the Applicant's debt or equity.**

NAME: \_\_\_\_\_ TITLE: \_\_\_\_\_

STREET: \_\_\_\_\_

CITY, STATE, ZIP: \_\_\_\_\_

NAME: \_\_\_\_\_ TITLE: \_\_\_\_\_

STREET: \_\_\_\_\_

CITY, STATE, ZIP: \_\_\_\_\_

NAME: \_\_\_\_\_ TITLE: \_\_\_\_\_

STREET: \_\_\_\_\_

CITY, STATE, ZIP: \_\_\_\_\_

**13. List all legal entities, in which the Applicant holds a debt or equity interest of more than five percent (5%).**

NAME: \_\_\_\_\_ TITLE: \_\_\_\_\_

STREET: \_\_\_\_\_

CITY, STATE, ZIP: \_\_\_\_\_

NAME: \_\_\_\_\_ TITLE: \_\_\_\_\_

STREET: \_\_\_\_\_

CITY, STATE, ZIP: \_\_\_\_\_

NAME: \_\_\_\_\_ TITLE: \_\_\_\_\_

STREET: \_\_\_\_\_

CITY, STATE, ZIP: \_\_\_\_\_

**14. List any parent company of the Applicant. Describe the parent company's ongoing organizational relationship with the Applicant.**

NAME: \_\_\_\_\_

STREET: \_\_\_\_\_

CITY, STATE, ZIP: \_\_\_\_\_

**Organizational Relationship:**

**15. List any subsidiary of the Applicant. Describe the subsidiary's ongoing organizational relationship with the Applicant.**

NAME: \_\_\_\_\_

STREET: \_\_\_\_\_

CITY, STATE, ZIP: \_\_\_\_\_

**Organizational Relationship:**



16. List any person who is not now in compliance or has a history of noncompliance with the environmental law or regulations of this state or any other jurisdiction and who through relationship by blood or marriage or through any other relationship could be reasonably expected to significantly influence the Applicant in a manner which could adversely affect the environment.

NAME: \_\_\_\_\_ TITLE: \_\_\_\_\_

STREET: \_\_\_\_\_

CITY, STATE, ZIP: \_\_\_\_\_

NAME: \_\_\_\_\_ TITLE: \_\_\_\_\_

STREET: \_\_\_\_\_

CITY, STATE, ZIP: \_\_\_\_\_

17. List all federal environmental agencies and any other environmental agencies outside this state that have or have had regulatory responsibility over the Applicant.

EPA

**18. VERIFICATION AND ACKNOWLEDGEMENT**

The Applicant agrees to provide any other information the director of the Arkansas Department of Environmental Quality may require at any time to comply with the provisions of the Disclosure Law and any regulations promulgated thereto. The Applicant further agrees to provide the Arkansas Department of Environmental Quality with any changes, modifications, deletions, additions or amendments to any part of this Disclosure Statement as they occur by filing an amended Disclosure Statement.

**DELIBERATE FALSIFICATION OR OMISSION OF RELEVANT INFORMATION FROM DISCLOSURE STATEMENTS SHALL BE GROUNDS FOR CIVIL OR CRIMINAL ENFORCEMENT ACTION OR ADMINISTRATIVE DENIAL OF A PERMIT, LICENSE, CERTIFICATION OR OPERATIONAL AUTHORIZATION.**

**COMPLETE THIS SECTION ONLY IF SUBMITTING OTHER THAN BY EPORTAL:**

I, Rick Ferguson, certify under penalty of law that this document and all attachments were prepared under my direction or supervision in accordance with a system designed to assure that qualified personnel properly gather and evaluate the information submitted. Based on my inquiry of the person or persons who manage the system, or those persons directly responsible for gathering the information, the information submitted is, to the best of my knowledge and belief, true, accurate, and complete. I am aware that there are significant penalties for submitting false information, including the possibility of fines and imprisonment for knowing violation.

APPLICANT  
SIGNATURE: \_\_\_\_\_



TITLE: President

DATE: 8-24-2020